

TempGuard Interfaces

AMP Junior & Mini Timer Connector Interface



Technical Characteristics

Conforms to	CE Mark to the low voltage directive RoHS Compliant to 2011/65/EU Conforms with end of life vehicle directive (ELV)EU200/53/EC			
Approvals and Standards				
Degree of mechanical protection	High			
Degree of protection	IP40 - Hinged Connector Interface fittings			
UV protection	Medium			
Finish	Dark Orange			
Application	Single junction straight and 90° elbow fittings providing high integrity connections between AMP Superseal or Junior timer connectors and Harnessflex conduit systems. In addition, 90° elbow versions allow the conduit to swivel 360° around the connector housing, sufficient to avoid the problems associated with one-piece interfaces of overflexing due to movement or vibration.			
Normal operating temperature range	Minimum Temperature	Permanent Max Temperature	Long Term Max Temperature (30,000 Hrs)	Short Term Max Temperature (3000 Hrs)
	-40°C	+160°C	+185°C	+200°C
For use with - Conduit range	Full TempGuard system protection is achieved using these fittings with HTC conduit. Compatible with all Harnessflex conduits.			
Fire Performance	Test Standard	Performance Rating		
	UL94	V2		
	UL94 RTI	150 (Elec)		
Chemical resistance & Storage data	Click or See page 4			
Type of material	High Temperature Polyamide (Nylon) - Low Smoke & Halogen Free			

Image



TempGuard Interfaces



AMP Junior & Mini Timer Connector Interface

SPECIALIST CONDUIT SYSTEMS

Dimensional Data & Part Number Configuration

Straight Interface * Stocked Item	A	B	C	D	Conduit Size (NC)	Conduit Size (NW)	AMP - Reference
CIH08-AM2	24.9	21.3	18	10	08	7.5	AMP Junior & Mini 2-way
CIH08-AM3	24.9	27.2	18	10	08	7.5	AMP Junior & Mini 3-way
CIH08-AM4	37.0	32.0	19	10	08	7.5	AMP Junior & Mini 4-way
CIH12-AM2	24.9	21.3	18	10	12	10	AMP Junior & Mini 2-way
CIH12-AM4	37.0	32.0	19	10	12	10	AMP Junior & Mini 4-way

Straight Interface ** Made to Order	A	B	C	D	Conduit Size (NC)	Conduit Size (NW)	AMP - Reference
CIH08-AM1	23.6	16.1	18	10	08	7.5	AMP Junior & Mini 1-way
CIH08-AM3	22.4	26.5	18	10	08	7.5	AMP Junior & Mini 3-way
CIH08-AM4	34	33	18	10	08	7.5	AMP Junior & Mini 4-way
CIH10-AM2	34	21	20	10	10	8.5	AMP Junior & Mini 2-way
CIH10-AM3	34	27	20	10	10	8.5	AMP Junior & Mini 3-way
CIH10-AM4	34	33	20	10	10	8.5	AMP Junior & Mini 4-way
CIH12-AM1	23.6	16.1	18	10	12	10	AMP Junior & Mini 1-way
CIH12-AM3	22.4	26.5	18	10	12	10	AMP Junior & Mini 3-way

Note : Nominal Dimensions are in mm

* Part numbers listed are stocked items available for immediate order

** Parts numbers listed are available to order but not stocked items, and would therefore be subject to manufacturing leadtime.

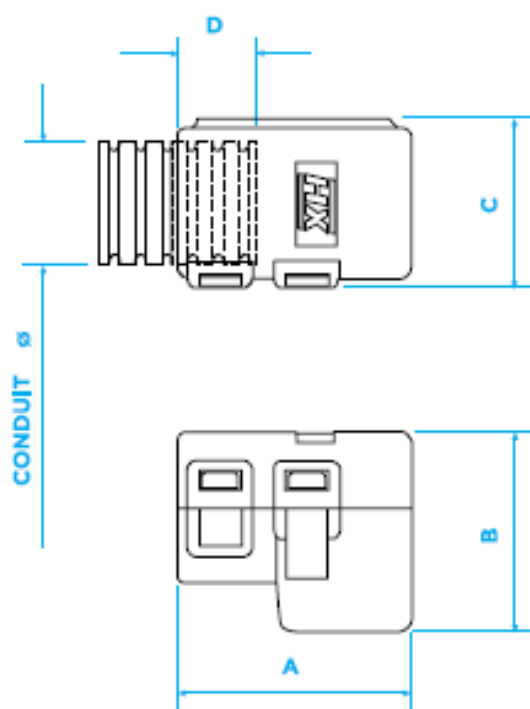

A Member of the ABB Group

TempGuard Interfaces



AMP Junior & Mini Timer Connector Interface

SPECIALIST CONDUIT SYSTEMS

Dimensional Data & Part Number Configuration

90° Elbow Interface * Stocked Items	A	B	C	D	Conduit Size (NC)	Conduit Size (NW)	AMP - Reference
CIH08-90-AM2	35.7	30.3	21.3	7.0	08	7.5	AMP Junior & Mini 2-way
CIH08-90-AM3	35.7	30.3	27.2	7.0	08	7.5	AMP Junior & Mini 3-way
CIH08-90-AM4	39.5	30.3	32.0	7.0	08	7.5	AMP Junior & Mini 4-way
CIH12-90-AM2	35.7	30.3	21.3	7.0	12	10	AMP Junior & Mini 2-way

90° Elbow Interface ** Made to Order	A	B	C	D	Conduit Size (NC)	Conduit Size (NW)	AMP - Reference
CIH08-90-AM1	37.5	30.3	18.0	10	08	7.5	AMP Junior & Mini 1-way
CIH10-90-AM2	35	38	19	10	10	8.5	AMP Junior & Mini 2-way
CIH10-90-AM3	35	38	19	10	10	8.5	AMP Junior & Mini 3-way
CIH10-90-AM4	41.2	38	19	10	10	8.5	AMP Junior & Mini 4-way
CIH12-90-AM1	33.3	30.3	18	10	12	10	AMP Junior & Mini 1-way
CIH12-90-AM3	33.3	30.3	26.7	10	12	10	AMP Junior & Mini 3-way
CIH12-90-AM4	37	30.3	33	10	12	10	AMP Junior & Mini 4-way

Note : Nominal Dimensions are in mm

* Part numbers listed are stocked items available for immediate order

** Parts numbers listed are available to order but not stocked items, and would therefore be subject to manufacturing leadtime.

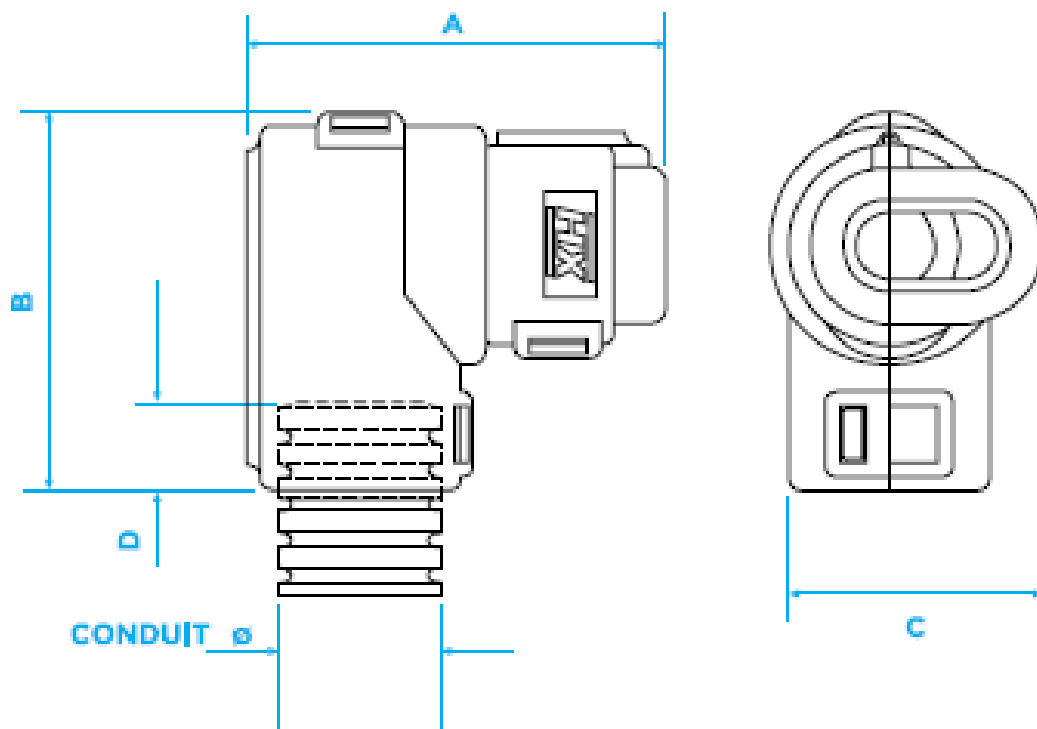

TempGuard Interfaces

AMP Junior & Mini Timer Connector Interface



Chemical Resistance Chart

Key: Suitable : ● Limited Suitability : ● Unsuitable : ● Not Tested : ●	● Astm No.1	● Diesel oil	● Methyl Bromide	● Sulphur Dioxide (Gas)
	● Astm No.2	● Diethylamine	● MEK	● Sulphuric Acid (10%)
	● Astm No.3	● Ethanol	● Nitric Acid (10%)	● Sulphuric Acid (70%)
	● Acetic Acid (10%)	● Ether	● Nitric Acid (70%)	● Toluene
	● Acetone	● Ethylamine	● Oxalic Acid	● Transformer Oil
	● Aluminium Chloride	● Ethylene Glycol	● Ozone (Gas)	● 1,1,1-Trichloroethane
	● Aniline	● Ethyl Ethanoate	● Paraffin oil	● Trichloroethylene
	● Benzaldehyde	● Freon 32	● Petrol	● Turpentine
	● Benzene	● Hydrochloric Acid (10%)	● Phenol	● Urea
	● Carbon tetrachloride	● Hydrochloric Acid (36%)	● Sea Water	● Uric Acid
	● Chlorine water	● Hydrogen Peroxide (35%)	● Silver Nitrate	● Vegetable Oil
	● Chloroform	● Hydrogen Peroxide (87%)	● Skydrol	● Vinyl Acetate
	● Citric Acid	● Lactic Acid	● Sodium Chloride	● Water
	● Copper Sulphate	● Lubricating oil	● Sodium Hydroxide (10%)	● White Spirit
	● Cresol	● Methanol	● Sodium Hydroxide (60%)	● Zinc Chloride

The information above is given as a guide only and is based on published technical data and experience. The chemical resistance of the above products is dependant on factors such as chemical exposure, concentration of the chemical and temperature. The above chemicals are valid for a temperature of 23°C. Use of the above table is at the users own discretion and risk. Those using it must satisfy themselves that their application presents no health and safety risks. The end user should assess compatibility with their application and contact Thomas & Betts for further information.

ADHERENCE TO THE CURRENT WIRING REGULATIONS BS7671 OR NEC WIRING REGULATIONS (FOR USA) IS STRONGLY ADVISED.

MINIMUM BEND RADIUS FOR FLEXING IS DEPENDANT UPON MINIMUM TEMPERATURE, BENDING FREQUENCY AND CHEMICAL ENVIRONMENT.

Storage Guidelines

To maintain balanced moisture content, Harnessflex recommends storing products under the following conditions:

Storage temp. 18°C to 30°C	Installation temp. >18°C	Rel. humidity >30%
--------------------------------------	------------------------------------	------------------------------

If products from an outside environment are brought into a heated processing area, the change in climate may suddenly cause temporary de-moisturisation around the edges. After 24 hours in the processing area a natural balance will be restored.

Observing this storage recommendation ensures optimum process-ability and material properties.