

## Type 1005 Commercial Gauge



Shown with Optional Rubber Boot

### FEATURES

- Case material is black-painted steel
- These gauges have a heat-resistant push-in polycarbonate window
- Dial faces match other Ashcroft® commercial gauges for easy readability
- Patented PowerFlex™ movement with polyester segment
- True Zero™ indication, a unique safety feature

Ashcroft® Type 1005 pressure gauges share the uncompromising reputation for quality and product integrity that is inherent in all Ashcroft instruments. The core of the Type 1005 gauge is the patented PowerFlex™ movement. This movement has been thoroughly tested and proven to be more resistant to shock, vibration, and pulsation than conventional movements, thus assuring a more accurate, dependable, long-lasting gauge.

The essence of Ashcroft Type 1005 gauges is attractive styling, a technically superior design, durable construction, economy, and the excellent reputation of Ashcroft gauges for delivery and service.

True Zero™ indication, a unique safety feature standard on these gauges, is the accurate indication of zero pressure being applied to the gauge. In addition to the increased safety benefits, this means reduced inspection and manufacturing costs for you and your customer.

### COMMONLY USED ON

*Compressors, filter regulators, fluid power equipment, medical equipment, pool and spa filters, automotive diagnostic equipment, beverage dispensing equipment, industrial machinery, a variety of other applications*

### PRODUCT SPECIFICATIONS

<b>Ashcroft® Model No.:</b>	1005
<b>Sizes:</b>	1½", 2", 2½", 3½"
<b>Case:</b>	Black painted steel
<b>Window:</b>	Polycarbonate
<b>Dial:</b>	Black figures on white background, aluminum
<b>Pointer:</b>	Black, aluminum
<b>Bourdon Tube:</b>	C-shape bronze (2"–3½", vacuum–600 psi and compound; 1½", vacuum–1000 psi) Helical bronze (2"–3½", 1000–6000 psi)
<b>Movement:</b>	PowerFlex™ with polyester segment
<b>Socket:</b>	Brass
<b>Restrictor:</b>	.013" orifice throttle plug in gauges 1000 psi and above
<b>Connections:</b>	½ and ¾ NPT, lower and back (1½" not available in ¾ NPT)
<b>Ranges:</b>	1½" Vac-1000 psi only 2", 2½" Vac-6000 psi and compound 3½" Vac-6000 psi and compound
<b>Accuracy:</b>	ASME B40.100, Grade B, ±3-2-3%
<b>Operating Temperature:</b>	–40°F to 150°F, –40°C to 65°C

### OPTIONAL FEATURES

<b>Case:</b>	Case color (other than black) Vent hole
<b>Pointer:</b>	Adjustable, Min/max assembly
<b>Movement:</b>	FlutterGuard™
<b>Socket:</b>	Non-standard length or thread Throttle plugs – 0.007", 0.013", 0.020", 0.063" Nickel plated, Teflon taped Top or side connection
<b>Dials:</b>	Customized Non-standard ranges Receiver ranges - 0/100 linear, 0/100 percent, 0/10 sq. root
<b>Others:</b>	UL 404 and UL 252A listing for compressed gas service Friction fit ring with glass window Bulk Packaging Black Rubber Gauge Boots for lower connect gauges

### HOW TO ORDER (Typical example)

		<b>20</b>	<b>W</b>	<b>1005</b>	<b>H</b>	<b>02L</b>	<b>XAP</b>	<b>100#</b>
<b>Dial Size:</b> 2"	_____							
<b>Movement:</b> Patented PowerFlex™	_____							
<b>Case Type Number:</b> 1005	_____							
<b>Socket Material:</b> Brass	_____							
<b>Connection Size/Location:</b> ½ NPT Lower	_____							
<b>Option:</b> Adjustable Pointer	_____							
<b>Range:</b> 100 psi	_____							

## Type 1005 Commercial Gauge

### DIMENSIONS

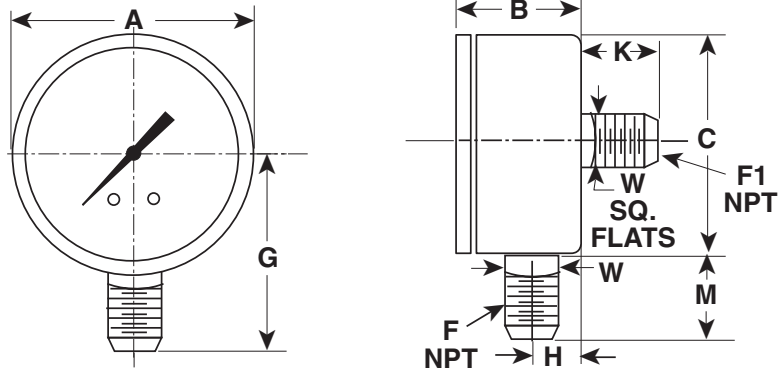

DIAL SIZE inches (mm)	A	B		C	F NPT	F1 NPT	G	H	K	M	W		WEIGHT OZ / KG	
		LOWER	BACK								LOWER	BACK		
1½"	1.62 (42)	0.86 (22)	0.99 (25)	1.60 (41)	¼	¼	1.46 (37)	0.28 (7)	0.67 (17)	0.66 (17)	0.56 (14)	0.44 (11)	2.05 oz 0.058 kg	1.98 oz 0.056 kg
2"	2.09 (53)	1.04 (26)	1.04 (26)	2.05 (52)	¼ or ¼	¼ or ¼	1.85 (47)	0.34 (9)	0.88 (22)	0.82 (21)	0.56 (14)	0.56 (14)	3.10 oz 0.088 kg	3.67 oz 0.104 kg
2½"	2.73 (69)	1.10 (28)	1.07 (27)	2.68 (68)	¼ or ¼	¼ or ¼	2.18 (55)	0.36 (9)	0.88 (22)	0.84 (21)	0.56 (14)	0.56 (14)	4.52 oz 0.128 kg	4.09 oz 0.116 kg
3½"	3.67 (93)	1.21 (31)	1.21 (31)	3.61 (92)	¼ or ¼	¼ or ¼	2.72 (69)	0.43 (11)	0.88 (22)	0.92 (23)	0.56 (14)	0.56 (14)	6.56 oz 0.186 kg	5.57 oz 0.158 kg