

SHUT DOWN DEVICES - PROFLO® Jr.

PRODUCT DESCRIPTION

The Proflo® Jr. monitoring device provides shut-down protection for your compressor based on the operation of the cycle times of the divider block system. If the pump deteriorates or if the lubricant flow slows down, the cycle time of the lube system will fall below the specified alarm time. This will prompt the Proflo® Jr. to change to alarm state and shutdown the compressor, preventing damage to the compressor cylinders, pistons, rods and packing.

FEATURES

- 3.3 volt hermetically sealed high temperature battery
- AC or DC operation, switch rated for 300 VDC and 120 VAC @.5 amps
- Patented sealed magnet assembly, No lost magnets, springs or spacers EVER
- Heavy duty magnet housing eliminated possibility of failure caused by bending
- Proximity switch output is standard with every unit
- Hall effect activated
- Field replaceable battery
- For CPI HP/XD/DropsA/Trabon/SB/Lincoln divider block/valve applications
- Blinking LED cycle indication
- Monitors movement of divider block piston for "timed" shutdown protection
- Closed loop or open loop operation
- Requires no external power
- Up to 10 year battery life, 5 year battery warranty

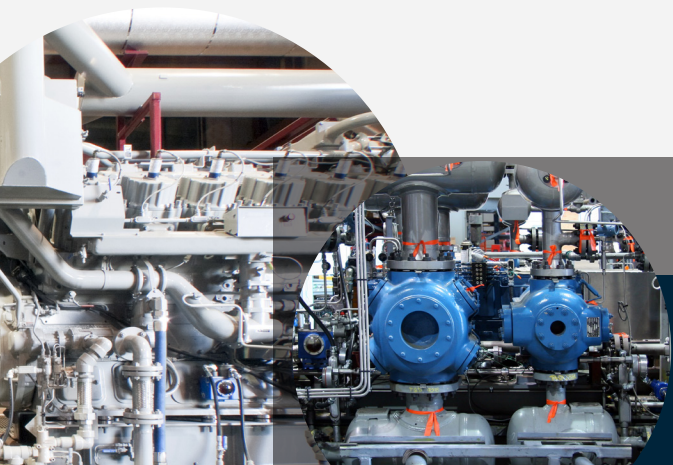

TECHNICAL SPECIFICATIONS

ALARM TIME	2 Minutes
MATERIAL	Aluminum Housing
TEMPERATURE RANGE	-40°F to 185°F
SWITCH RATING	0.5A/300VDC
EPOXY ENCAPSULATED	UL Listed EL-CAST VFR 641
POWER	Field Replaceable Battery

RATINGS

Explosion proof

CSA Certified

CE Certified

KEMA 00ATEX1090 X AMB. -40°C to +85°C

Class 1, Division 1, Group A, B, C, D, and T4

Certifications:

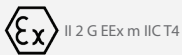

KEMA 00ATEX1090 X Amb. -40°C...+80°C

Magnet Assemblies

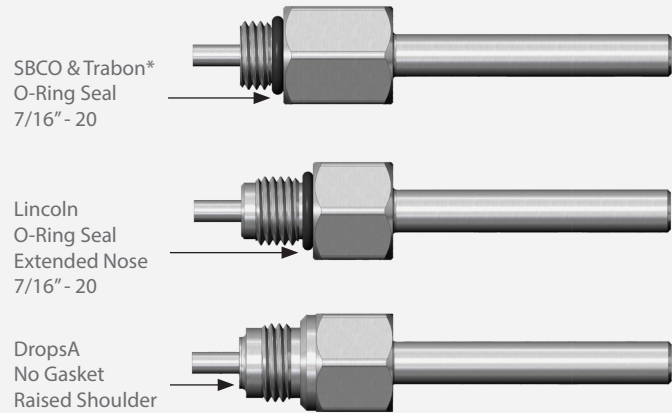

*For use on CPI HP+ and XD+ Divider Blocks

Proflo® Jr. Models with Magnet Assembly

PART NO.	DESCRIPTION
650040000PFJRT	Proflo® Jr. with Magnet Assembly (Trabon)
650040000PFJRD	Proflo® Jr with Magnet Assembly (DropsA)
650040000PFJRL	Proflo® Jr with Magnet Assembly (Lincoln)

Replacement Proflo® Jr Components

PART NO.	DESCRIPTION
65004000PFJRTMA	Proflo® Jr Magnet Assembly (Trabon)
65004000PFJRDMA	Proflo® Jr Magnet Assembly (DropsA)
65004000PFJRLMA	Proflo® Jr Magnet Assembly (Lincoln)
65004000PFJRBAT	Proflo® Jr Replacement Battery

CPI provides industry leading lubrication system products and services, partnering with our customers to develop individual solutions to their unique lubrication needs. From individual components to complete, turnkey systems, we can provide the resources and expertise to ensure your compressor operates at peak performance and longevity.