

# PROFLO® PF1 AND PF1 24V SHUTDOWN DEVICES

## PRODUCT DESCRIPTION

The Proflo® PF1 monitoring device provides shutdown protection for your compressor and collects operation data by monitoring the cycle times of the divider block system. If the pump fails or the cycle time of the divider block system slows down or speeds up, the Proflo® PF1 alerts the operator by displaying the changed cycle time on the LCD display. If the pump deteriorates, the cycle time will slow down and the Proflo® PF1 will change to alarm state and shut down the compressor, preventing damage to the compressor cylinders, pistons, rods and packing. The system data can be retrieved and analyzed using our Proflo™ USB-IR adaptor and Proflo™ Assist software.

## FEATURES

- Trends and stores divider block system operation to monitor:
  - Oil consumption / over- and under-lubrication
  - Lubricator pump failure
  - Divider block failure
  - Compressor component failure (rings, rods, packing and cylinders)
  - compressor run time
- Shuts down compressor when lubrication system fails or begins to deteriorate
- Adjustable alarm time (20 seconds to 255 seconds)
- Installs on divider block or in control panel
- Wireless (IRDA) download of trending information to your computer using the Proflo™ USB-IR Adaptor

### Proflo® PF1 24V Model:

- Uses 2 "AA" Lithium batteries\* for back-up power to the microprocessor when the control panel is turned off or the power fails
- Battery life is approximately 24 months

\* Use L91 Energizer Lithium "AA" only

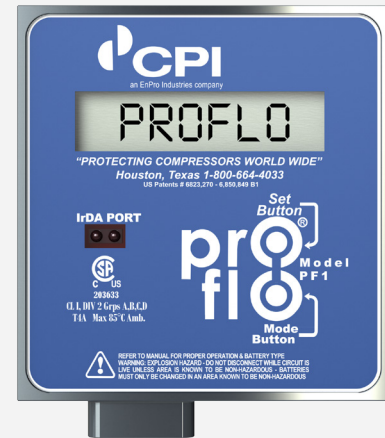

Class 1 : Div 2; Grps A, B, C, D, T4

## MAGNET ASSEMBLIES

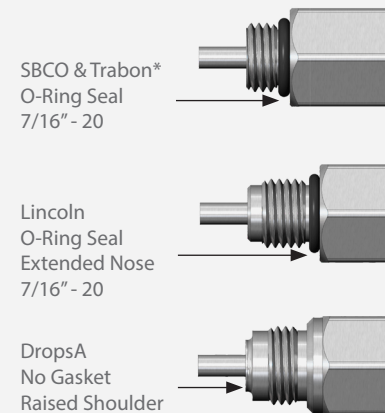

\*For use on CPI HP+ and XD+ Divider Blocks

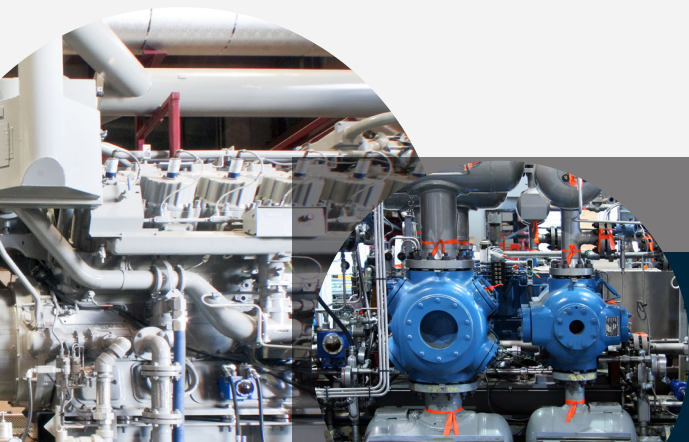

Proven Solutions for the Global Compression Industry™

## TECHNICAL SPECIFICATIONS

<b>MATERIAL</b>	Aluminum or Stainless Housing
<b>TEMPERATURE RANGE</b>	-40°F to 185°F
<b>SWITCH RATING</b>	30 VDC - 200 mA max
<b>EPOXY</b>	Resin Labs EP1295
<b>POWER</b>	Field Replaceable Battery
<b>ALARM TIME</b>	2 Minute Standard (LED) 3 Minute Standard (LED)

User programmable between 20 seconds - 4 minutes and 15 seconds (PRG)

## PROFLO™ USB-IR ADAPTOR AND PROFLO™ ASSIST SOFTWARE

### For Proflo® PF1 and PF1 24V

- Portable USB IR reader
- Retrieve data from PF1 that has been stored for months
- User-friendly software to graph, trend and save data
- Data shows pump adjustments needed to result in optimum performance

Developed by CPI, the Proflo™ USB-IR Adaptor allows the operator to download up to a year of divider block system data from the Proflo® PF1 monitor to a computer.

The data can be viewed with the Proflo™ Assist software to show total divider block systems, divider block volume, total cycles, total runtime, alarm time, alarm mode, days logged, operational days, and total oil consumed. Graphs provide visibility to trends such as average cycle time over time.

The software in conjunction with the Proflo® PF1 allows you to anticipate trouble and make adjustments on existing lubrication pumps to reduce over- or under-lubrication, before unscheduled, costly downtime occurs.

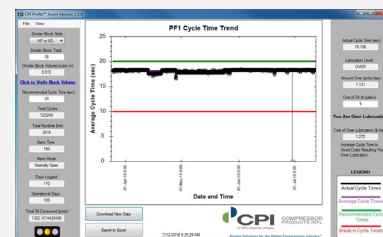

### Proflo® PF1 Models (with Magnet Assembly)

PART NO.	DESCRIPTION
6500400000PF1T	Proflo® PF1 with Magnet Assembly (Trabon)
6500400000PF1D	Proflo® PF1 with Magnet Assembly (DropsA)
6500400000PF1L	Proflo® PF1 with Magnet Assembly (Lincoln)
65004000PF124VT	Proflo® PF1 24V with Magnet Assembly (Trabon)
65004000PF124VD	Proflo® PF1 24V with Magnet Assembly (DropsA)
65004000PF124VL	Proflo® PF1 24V with Magnet Assembly (Lincoln)

### Proflo® PF1 Replacement Components, Kits & Accessories

PART NO.	DESCRIPTION
650040000PF1TMA	Proflo® PF1 Magnet Assembly (Trabon)
650040000PF1DMA	Proflo® PF1 Magnet Assembly (DropsA)
650040000PF1LMA	Proflo® PF1 Magnet Assembly (Lincoln)
65004000PF1BATT	Proflo® PF1 Replacement Batteries
650040000PFUSB	Proflo™ USB-IR Adaptor & Software
65004000PF1TUSB	Proflo® PF1 with Magnet Assembly (Trabon) and USB-IR Adaptor & Assist Software
65004000PF1DUSB	Proflo® PF1 with Magnet Assembly (DropsA) and USB-IR Adaptor & Assist Software
65005000PF1LUSB	Proflo® PF1 with Magnet Assembly (Lincoln) and USB-IR Adaptor & Assist Software
65004PF124VTUSB	Proflo® PF1 24V with Magnet Assembly (Trabon) and USB-IR Adaptor & Assist Software
65004PF124VDUSB	Proflo® PF1 24V with Magnet Assembly (DropsA) and USB-IR Adaptor & Assist Software
65004PF124VLUSB	Proflo® PF1 24V with Magnet Assembly (Lincoln) and USB-IR Adaptor & Assist Software

CPI provides industry leading lubrication system products and services, partnering with our customers to develop individual solutions to their unique lubrication needs. From individual components to complete, turnkey systems, we can provide the resources and expertise to ensure your compressor operates at peak performance and longevity.

Proven Solutions for the Global Compression Industry™