

# Endura™ 8000 Series Swivel Manual Dual Split Flange (DSF) Swivel Joint

The Dual Split Flange (DSF) Swivel from OPW Engineered Systems represents the best available swivel technology. Specifically designed for the transfer of hazardous materials such as acids, solvents, petrochemicals and other toxic fluids, Endura™ sets the standard in swivel performance.

## Benefits

- **Endurance** - Heavy-duty construction and unique design features result in long-life, hassle-free operation.
- **Improves Uptime Performance** - Endura™ DSF swivel technology, combined with the most user-friendly counterbalance solutions, results in less downtime, less labor, less cost!
- **Lowest Overall Cost of Ownership** - Optimized performance, downtime prevention and reduced maintenance time and costs make this the best overall loading-arm solution currently available.

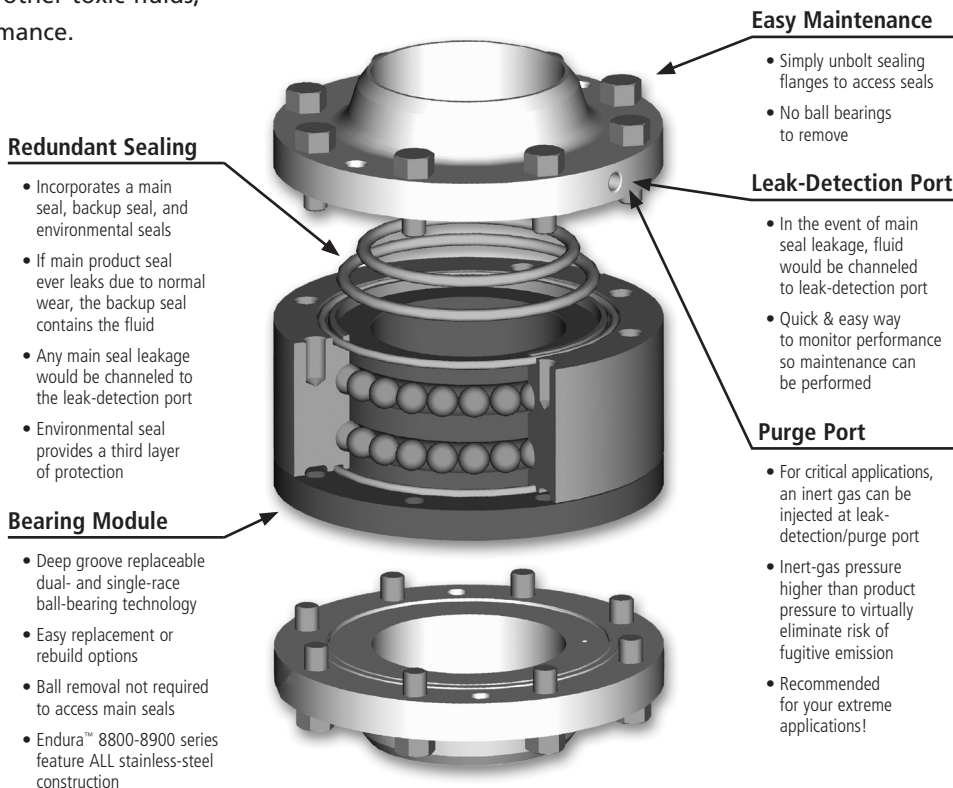

## Selection Guide

**84 20 F - 03 01**

Module Style	Swivel Style	End Connections	Size	Seals
82 - Single-Race Steel	20 1 plane of rotation	F - 150 x 150	02 - 2"	01 - Buna-N
84 - Dual-Race Steel	30 1 plane of rotation	W - Weld x Weld	03 - 3"	02 - Fluorocarbon
87 - Single-Race Stainless Steel	40 1 plane of rotation	FO - 150 x FNPT	04 - 4"	03 - PTFE Silicone (FDA-Approved)
89 - Dual-Race Stainless Steel	50 2 planes of rotation	FW - 150 x Weld		04 - EPDM
	60 2 planes of rotation			09 - Kalrez® 6375
	70 2 planes of rotation			

## Design Parameters

(EN13480:2002 part 1-7), ASME B31.3

## Maximum Design Pressure

500 psi/34 bar

## Main and Backup Seals

	Min Temp (F/C)	Max Temp (F/C)
Buna-N 1500	-20°F/-28.8°C	212°F/100°C
Fluorocarbon (V1163-75)	-20°F/-28.8°C	400°F/204.4°C
PTFE (PFA)-encapsulated Silicone (FDA-Approved)	-50°F/-45.6°C	500°F/260°C
EPDM	-50°F/-45.6°C	250°F/121°C
Kalrez®	0°F/-17.7°C	500°F/260°C

All Endura™ DSF Swivels come standard with specified main and backup seals. PTFE-encapsulated Fluorocarbon environmental seals (qty. 2) and static product seals (qty. 1) are standard. Other seals available upon request.

## Seal Kits

Size/DN	Buna-N 1500	Fluoro-carbon	PTFE/Silicone	EPDM	Kalrez®
2" / DN 50	8400RK-0201	8400RK-0202	8400RK-0203	8400RK-0204	8400RK-0209
3" / DN 80	8400RK-0301	8400RK-0302	8400RK-0303	8400RK-0304	8400RK-0309
4" / DN 100	8400RK-0401	8400RK-0402	8400RK-0403	8400RK-0404	8400RK-0409

All Endura™ DSF Seal Kits include (2) Main seals, (1) Backup seal and (3) PTFE-encapsulated Fluorocarbon environmental seals. Also included are required seal spacers and hardware.

## Lubricants

Product	Description
880-0089	High-Performance Synthetic Lubricant (14 oz. (400 grams) cartridge) <ul style="list-style-type: none"> <li>Specially formulated to reduce friction and wear</li> <li>Requires only annual lubrication</li> <li>Will not drip, melt or carburize</li> <li>Complies with FDA Regulation 21CFR 178.3570</li> <li>Temperature Range: -40°F - 750°F (-40°C - 398.8°C)</li> <li>Not for use with EPT/EPDM Seals</li> </ul>
885-0085	High-Performance Synthetic Lubricant for EPT Seals

**Warning:** EPT/EPDM requires the use of OPW 885-0085 lubricant or a non-petroleum-based lubricant.

MATERIALS	CARBON STEEL 8300 / 8400	STAINLESS STEEL 8800 / 8900
Sealing Flange	ASTM A350-LF2 Class 1	ASTM A351-CF3M
Body	ASTM A350-LF2 Class 1*	ASTM A351-CF3M
Tail	ASTM A350-LF2 Class 1*	ASTM A351-CF3M
Elbow	ASTM A234 WPB	ASTM A351 CF3M 316L
150/300 lb Flange	ASTM A105	ASTM A351 CF3M 316L
Bearing	Grade 200 CST	Grade 440 SST
Bolt	A193 B7	A193 B8M Class 2
Ball Plug/Nut	Carbon Steel	Stainless Steel
Grease Fittings	Stainless Steel	Stainless Steel

\*Carburized to RC 45-60

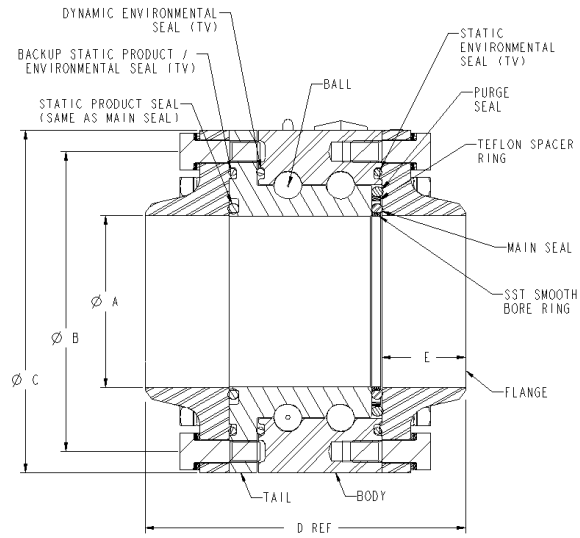

**NOTE:** Dimensional drawings for standard styles available via download section of website ([www.opw-es.com](http://www.opw-es.com))

## Dimensions

Description	Type	2" (DN 50)		3" (DN 80)		4" (DN 100)	
		in	mm	in	mm	in	mm
Dimension A		2.067	52.5	3.064	79.8	4.06	103.18
Dimension B		4.61	117.1	5.36	136.1	6.9	175.3
Dimension C		5.33	135.4	6.13	155.8	7.84	199.1
Dimension D	Dual	5.725	145.4	5.725	145.4	6.175	156.8
	Single	4.81	122.2	4.81	122.2	5.25	133.4
Dimension E		1.5	38.1	1.5	38.1	1.5	38.1
		<b>ft-lbf</b>	<b>Nm</b>	<b>ft-lbf</b>	<b>Nm</b>	<b>ft-lbf</b>	<b>Nm</b>
Bolt Torque		28	38	28	38	75	102
		<b>lbs</b>	<b>kg</b>	<b>lbs</b>	<b>kg</b>	<b>lbs</b>	<b>kg</b>
Weight	Dual	21	9.53	26	11.79	44	19.96
	Single	16	7.26	20	9.07	35	15.88

# Endura™ 8000 Series Swivel

**Step 1:** Support and secure outboard weight of loading arm or swivel assembly with crane or lifting device while performing the following steps. It is recommended that the swivel be removed from the supporting loading arm prior to any seal maintenance. All torsion spring pre-load must be removed from torsion-spring prior to any swivel joint disassembly.

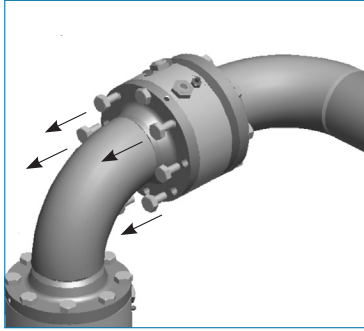

**Step 2:** Remove all split flange bolts on the side of the swivel attached to the free-moving end. With the bolts loosened, support this side of the loading arm along with any other parts attached to it that might move freely when the bolts are removed. Remove bolts, starting with lowest on flange, leaving top bolts for last. Be careful not to damage sealing flange module face and bolts.

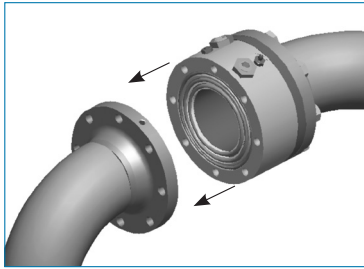

**Step 3:** Once the now-detached arm has been secured and put out of the way, remove the three (3) O-rings and two (2) O-ring spacers. Inspect and clean all machined surfaces to ensure that there are no nicks, scratches or burrs.

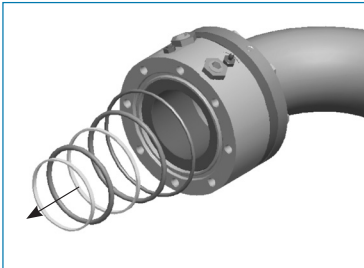

**Nord-Lok™ Washers –** Coarser serrations must face inward and lock together

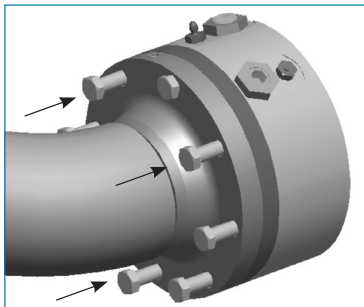

**Step 4:** With the rest of the loading arm still secured from movement, loosen the bolts on the other side of the swivel. Swivel module should fall away easily to expose environmental and O-ring seals. Secure product seal.

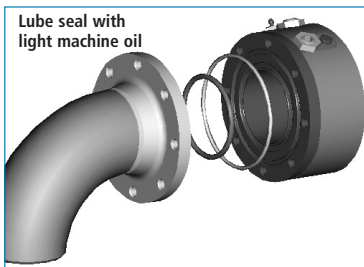

Lube seal with light machine oil

**Step 5:** Inspect and clean all machined surfaces. Press new static environmental and main seals into sealing grooves on swivel-module tail.

**Note:** Corrosion on any sealing surface may indicate need for component replacement.

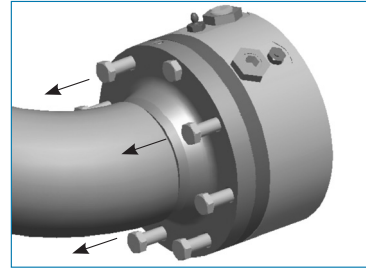

**Step 6:** Align flange with body and press surfaces together. Thread flange bolts with Nord-Lok™ washers into tail and torque to amount shown on chart. Nord-Lok™ washers come as an assembly bonded together from the factory. It is important that the correct

orientation be preserved for proper function. There are two different serration patterns on each side of the washer, with two washers in an assembly. The coarser serrations must face inward and lock together, while the finer serrations face outward and engage the bolts and mounting surface.

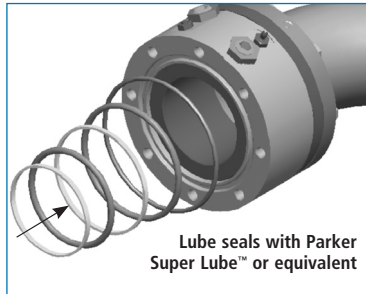
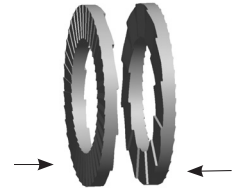

Lube seals with Parker Super Lube™ or equivalent

**Step 7:** Press static seal into swivel body outer groove, followed by placing purge seal inside recess created by tail and body. Set seal spacer ring inside purge seal, followed by main seal. Set SST smooth-bore ring inside main seal, then cap entire seal/spacer combination with sealing flange. Torque bolts to specified value.

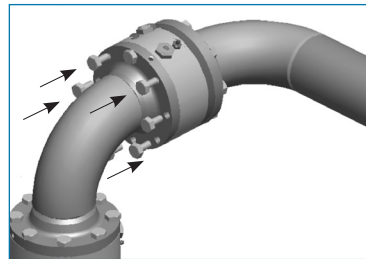

**Step 8:** Bolt sealing flange to body using bolts and Nord-Lok™ washers. Torque to amount shown on chart below.

## Suggested Maintenance Schedule

### SWIVEL INSPECTION - Monthly

General Inspection for ease of rotation and evidence of leakage. Any evidence of problem would indicate a need for further maintenance.

### SWIVEL LUBRICATION - Annually

It is recommended that each swivel module be lubricated with appropriate lubricant on an annual basis with manual grease gun.

### SEAL REPLACEMENT - Every 2 years

Replacing swivel seals with appropriate swivel-seal kit should be performed every 24 months, or at first evidence of leakage.

### OVERHAUL - Every 4 years

Complete overhaul of swivel module should be performed every 48 months, or at evidence of leakage into bearing module. This process would involve seal replacement AND complete disassembly of swivel module to inspect raceways and replace dynamic environmental seal.

BOLT TORQUE CHART	2"	3"	4"
Torque (ft-lbs)	28	28	75
Torque (Nm)	38	38	102

## Endura™ 8000 Maintenance

It is generally good practice to perform a complete swivel inspection/rebuild (overhaul) every 24 months. This helps ensure trouble-free operation without interruption of your process. It is also advisable to rebuild at evidence of product leakage into bearing module.

Exercise caution so as not to lose any balls when removing them from the swivel module during disassembly. Flushing the grease chamber with a suitable, non-flammable solvent will allow the balls to fall out freely. Be sure the same number of balls are returned to each raceway.

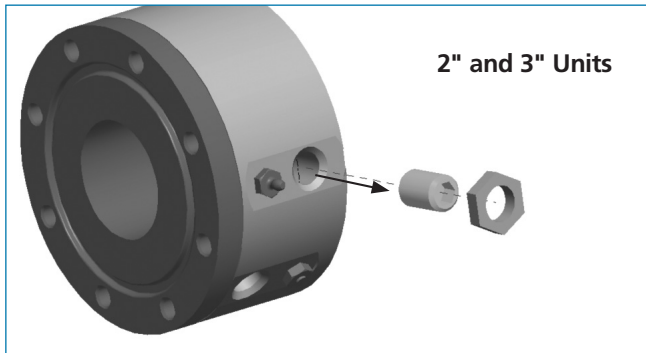

**Step 1:** Remove bearing plug bolts to access respective ball race.

NOTE: 4" units are provided with threaded hex bolt in lieu of threaded plug/jam-nut combination.

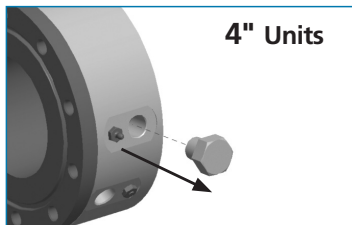

**Step 2:** Remove ball bearings via ball port in swivel body.  
NOTE: Non-flammable solvent may be used to help loosen lubricant and allow for easier ball removal.

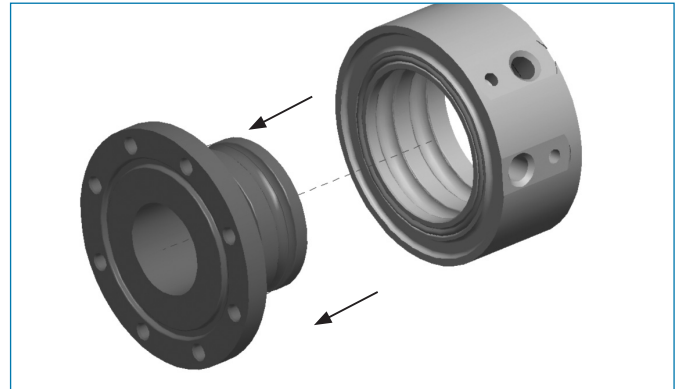
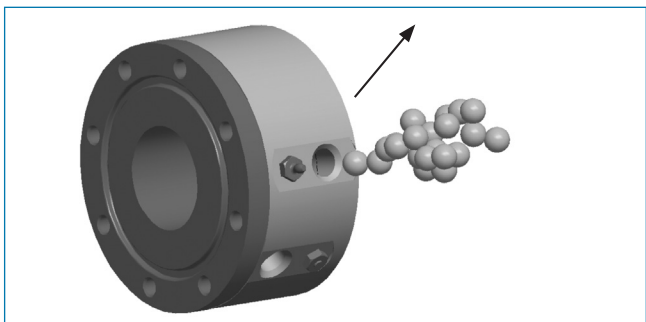
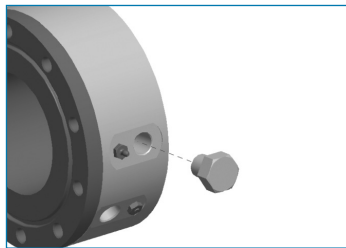

**Step 3:** After all balls have been removed, carefully remove swivel tail from swivel body.

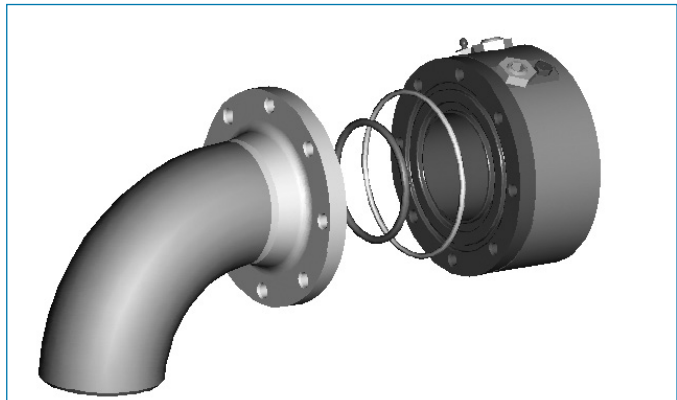

**Step 4:** Carefully remove dynamic environmental seal. Clean and inspect all machined surfaces and carefully press new environmental seal into groove. NOTE: Lube seal with light machine oil.

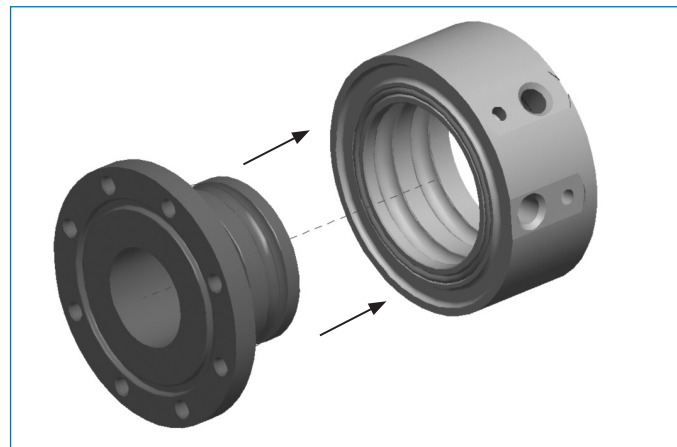

**Step 5:** Carefully align swivel tail and insert into body.

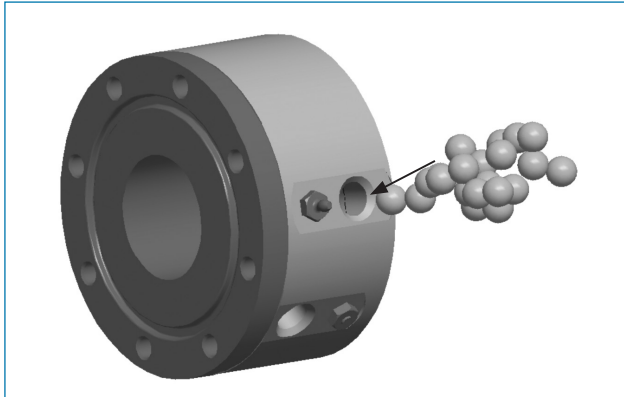

**Step 6:** Install ball bearings until bearing chamber is full. Chart below shows the number of bearings per race.

BEARINGS CHART	2"	3"	4"
Ball Bearings (qty.)	21	26	28

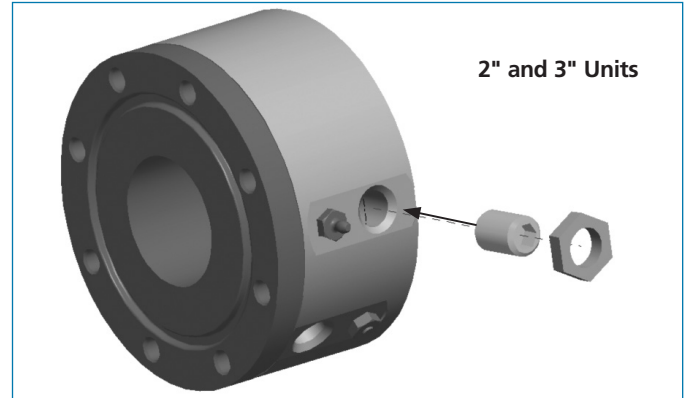

**Step 7a:** (2" and 3") With chamber completely full of bearings, rotate body/tail until one bearing is directly in-line with the threaded ball-plug hole.

Install the ball-bearing plug and tighten down until it is just snug on the ball bearing. Then install the jam nut. Loosen the ball-bearing plug by 1/2 to 3/4 of a turn and tighten jam nut.

**Step 7b:** (4") With chamber completely full, install bearing plug bolt and tighten down all the way.

**Step 8:** Repeat Step 5 through Step 7 from DSF Seal Replacement instructions.

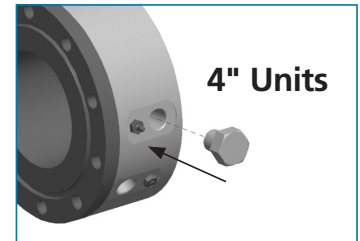

## Greaseless/Non-Lubricated Applications

OPW Swivels can be specified as greaseless, or non-lubricated, for certain applications. These swivels would typically be supplied as follows:

- Stainless Steel (Grade 440) Ball Bearings would be supplied in lieu of Carbon Steel Balls.
- Grease fitting (p/n H30823M) would be removed and replaced with threaded plug (p/n H03288M).
- A light coating of LPS2 (LPS Labs) shall be applied to seals prior to installation.

### WARNING

Failure to follow these warnings could result in serious personal injury, property damage or product failure.

1) Do not attempt any maintenance service while the equipment is in operation. System pressure must be relieved and the product drained before attempting any service on the unit. The line must be locked out while service is in progress. Proper thermal relief must be provided at all times while equipment is in service.

2) OPW products do not eliminate possible exposure to hazardous substances. The conditions of handling and use are beyond our control, and we make no guarantee and assume no liability for damages or injuries related to the use of our products. Follow the safety precautions outlined in the Material Safety Data Sheets for the material being used. It is the responsibility of the user to comply with all federal, state and local regulations. Always employ proper safety precautions and handling techniques.

3) Proper seal and wetted-material part selection is critical for safe operation. To assure maximum life for the service intended, use only those materials compatible with the fluids being handled. Please note material being supplied and make certain that it is suited for the intended service.

**IMPORTANT:** OPW products should be used in compliance with applicable federal, state, provincial, and local laws and regulations. Product selection should be based on physical specifications and limitations and compatibility with the environment and materials to be handled. OPW MAKES NO WARRANTY OF FITNESS FOR A PARTICULAR USE. All illustrations and specifications in this literature are based on the latest product information available at the time of publication. OPW reserves the right to make changes at any time in prices, materials, specifications and models and to discontinue models without notice or obligation.