



SKINNER 7000 Series **General Purpose Two-Way Direct Acting Valves**

IN THIS SECTION :
7121, 7122, 7123, 7129

SPECIFICATIONS

Mechanical Characteristics

Standard Materials of Construction

- Body – Brass or Stainless Steel (430F)
- Seals – NBR, FKM, PCTFE as listed, EPDM as listed
- Sleeve Tube – Stainless Steel (303 or 304)
- Plunger – Stainless Steel (430FR)
- Stop – Stainless Steel (430FR)
- Springs – Stainless Steel (18-8)
- Shading Rings – Copper
- Pilot Orifice – Stainless Steel (303)

Compatible Fluids

- Lubricated Air, Non-Lubricated Air, Inert Gases, Water, Hydraulic Fluids, Petroleum Products and additional fluids compatible with materials of construction. Use of non-lubricated gaseous media will substantially limit valve life.

Electrical Characteristics

Voltages

- DC – 12, 24
- AC – 24/60, 110/50-120/60, 208/60, 220/50-240/60, 440/50-480/60 (other AC/DC voltages available upon request)

Agency Approvals

- UL and CSA approvals are available on valves with applicable coil/enclosure combinations. For additional information see page 136.

Power Consumption

- 10, 22 watts
- Fluxtron Electronic Coils and Magnelatch (refer to page 137 for current draw charts)

Miscellaneous

Maximum Ambient Temperature

- 10 watt AC/DC – 150°F
- 22 watt AC/DC – 77°F
- Fluxtron/Magnelatch – 122°F

7121 DIRECT ACTING BRASS VALVES – NORMALLY CLOSED, PCTFE OR FKM SEALS

Pipe Size NPT	Orifice Size (inch)	Cv Factor	Operating Pressure Differential (PSI)				MAX.* Fluid Temp. (F)	Pressure Vessel Number	UL/CSA** Approval	Const. Ref.	
			Min.	Maximum		10 watt					22 watt
				10 watt	22 watt						
FLG [^]	1/16	0.11	0	1000	435	165	7121FBF4GF00	GP	1		
	1/8	0.31	0	365	125	165	7121FBF4NF00	GP	1		
1/8	1/16	0.11	0	1000	435	700	7121KBN1GF00	GP	2		
	1/8	0.31	0	365	125	205	7121KBN1NF00	GP	2		
1/4	1/16	0.11	0	1000	435	700	7121KBN2GF00	GP	2		
	1/8	0.31	0	365	125	205	7121KBN2NF00	GP	2		
	1/8	0.31	0	145	125	125	7121KBN2NV00	SS	2		
	5/32	0.52	0	120	60	75	7121KBN2QV00	SS	2		
	13/64	0.76	0	80	30	40	7121KBN2SV00	SS	2		
3/8	1/4	0.83	0	55	20	20	7121KBN3UV00	SS	2		
1/2	7/16	2.5	0	17.5	35	5	10	7121KBN44V00	SS	3	

[^] 2, 3 and 5 station subbases with 1/4" BSP common inlet port and 1/8" BSP outlet port are available for use with D400 and D500 32mm DIN coils only. For details consult factory.

7000 Series General Purpose Two-Way Direct Acting Valves

#6

Port Identification: 2-IN/ 1-OUT

#1

Port Identification: 1-IN/ 2-OUT

Valve	Dimension			
	H	P	C	L
7121KBN1XXXX	2.63	3.07	1.61	1.57
7121KBN2XXXX	2.63	3.07	1.61	1.57
7121KBN3XXXX	2.57	3.08	1.55	1.97

X denotes multiple digit combinations for brevity.

#2

Port Identification: 1-IN/ 2-OUT

#3

Port Identification: Flow arrow on body indicates flow direction—ports are not marked.



PRESSURE VESSEL NUMBERING 2-WAY VALVES

For reference only. Consult catalog listings for available combinations.

1	2	3	4	5	6	7	8	9	10	11 & 12	
	Actuation	Functional Type	Flow Pattern	Family*	Body Material	Threading/ Process Connection	Pipe Size (NPT)	Orifice Code#	Seals/+ Elastomers	Mech. Options	
7	1 Direct Acting 2 Direct Lift	2 Two-Way	1 Normally Closed 2 Normally Open pressure in/out of body Multi/Dual purpose	1 A 2 B	Aluminum Brass	A SAE E Male NPT	1 1/8" 2 1/4"	A B	C CR E EPDM	00 A2	No Option Silver Shading Ring
	3 Pilot Operated Internal Supply 4 Pilot Operated External Pilot Supply		3 9 Normally Open pressure in the body, pressure out the sleeve	4 L 5 R	Noryl 316 SS	F Flange G BSP-Parallel	3 3/8" 4 1/2"	C D	F PCTFE K PFFPM	C0 J1	4-Step Variable Closing Exhaust Adaptor Nut
	5 Remote Pressure Operated 6 Manual/Mech. Operated			6 S 8 T 9 V F G H K V	430F SS PTFE 303 SS	R BSP-Taper J Bib Fitting N NPT(Female Nat'l Pipe thread) T Barbed Fitting	5 3/4" 6 1" 7 1 1/4" 8 1 1/2" 9 2"	E F G H J K L M N P Q R S T U V 0 thru 9	L Nylon M Metal N NBR R Ruby T PTFE U PTFE V FKM	M0 MC M5 R0 R1 R2 S0 W0 N0	Manual Override Manual Override w/Var. Closing Manual Override w/Exhaust Adaptor Sleeve Exhaust Metering Mainstream Metering Adjustable Bypass Steam Service Rated Anti-Water Hammer (fixed) Cleaned for oxygen service

Note: These tables are provided to interpret product specifications. It should not be used to create a valve number without reference to the catalog listings or consultation with Skinner Valve personnel.

* The family designator is assigned to organize products by physical similarity.

Orifice codes relate to a range of Cv factors and sizes. They are listed in ascending order.

+ Reference Seal Material Designations, page 131.

PRESSURE VESSEL NUMBERING 3- AND 4-WAY VALVES

For reference only. Consult catalog listings for available combinations.

1	2	3	4	5	6	7	8	9	10	11 & 12	
	Actuation	Functional Type	Flow Pattern	Family*	Body Material	Threading/ Process Connection	Pipe Size (NPT)	Orifice Code#	Seals/+ Elastomers	Mech. Options	
7	1 Direct Acting 2 Direct Lift	3 Three-Way 4 Four-Way	3-Way Valves 1 Normally Closed 2 Normally Open pressure in/out of body 3 Multi/Dual Purpose	1 A 2 B 3 L	Aluminum Brass Noryl	A SAE E Male NPT F Flange	1 1/8" 2 1/4" 3 3/8"	A B C	C CR E EPDM F PCTFE	00 A2 CA	No Option Silver Shading Ring Cylinder "A" normally open to pressure inlet Cylinder "B" normally open to pressure inlet
	4 Pilot Operated Int. Pilot Supply 5 Pilot Operated Ext. Pilot Supply 6 Remote Pressure operated Manual/Mech. Operated		8 Diverting 9 Normally Open pressure in the sleeve, pressure out the body 4-Way Valves 1 2-position, single operator 2 3-position, dual operator center closed 3 3-position, dual operator center open 4 3-position, dual operator center open 6 2-position, dual operator bi-stable 7 2-position, dual operator bi-stable, with latching	4 M 5 R 6 S 8 T 9 V E F G H K L T V	Zinc Die Cast 316 SS 430F SS PTFE 303 SS	G BSP-Parallel R BSP-Taper J Bib Fitting N NPT (Female National Pipe Thread) S Subbase Mounted T Barbed Fitting	4 1/2" 5 3/4" 6 1" 7 1 1/4" 8 1 1/2" 9 2"	D E F G H J K L M N P Q R S T U V 0 thru 9	K PFFPM L Nylon M Metal N NBR R Ruby T PTFE U PTFE V FKM	CB C0 J0 J1 M0 MC MJ MR M5 R0 R1 R2 S0 W0 N0	4-Step Variable Closing Pilot Exhaust Return Pipe Exhaust Adaptor Nut Manual Override Manual Override w/Var. Closing Manual Override w/Exhaust Return Pipe Manual Override w/Main Stream Metering Manual Override w/Exhaust Adaptor Sleeve Exhaust Metering Mainstream Metering Adjustable Bypass Steam Service Rated Anti-Water Hammer (fixed) Cleaned for oxygen service

ENCLOSURE, COIL AND VOLTAGE NUMBERING 2-, 3- AND 4-WAY VALVES

13 & 14 Enclosure Type		15 & 16 Coil Construction and Type		17 & 18 Terminations and Option Codes		19 & 20 Voltage	
A0	7/8" Knockout		Integrated Coils	00	Standard DIN, Screw, Tab Coils (no leads)	B2	24/60
B0	1/2" Conduit	C1	1/2" NPT Conduit, 10 Watt Class F, NEMA 4X	11	Class F Coils with 18" leads	C1	12VDC
F0	Yoke	C2	1/2" NPT Conduit, 10 Watt Class H, NEMA 4X	22	Class H Coils with 18" leads	C2	24VDC
G0	Water Tight	C3	1/2" NPT Conduit, 22 Watt Class H, NEMA 4X	GL	C1,C2,C3 & H1,H2, H3 Coils with Ground lead	C4	48VDC
J0	Junction Box	D1	DIN, 10 Watt Class F	D1	All DIN Coils with Cable Gland Connector	C6	120VDC
M1	Magnelatch	D2	DIN, 10 Watt Class H	D2	All DIN Coils with 1/2" Conduit Connector	P0*	24,50/60
M2	1/2" Conduit Magnelatch Grommet	D3	DIN, 22 Watt Class H	D4	D1,D2,D4 coils for timer assembly with fixed-off and adjustable on-time	P3	110/50-120/60
N0	Nut and Washer	H1	1/2" NPT Conduit, 10 Watt Class F, NEMA 7, 9	DB	All DIN Coils with Terminal Box	Q3	220/50-240/60
		H2	1/2" NPT Conduit, 10 Watt Class H, NEMA 7, 9	TB	S1,S2,S3 Coils with Terminal Box	Q8	440/50-480/6
		H3	1/2" NPT Conduit, 22 Watt Class H, NEMA 7, 9	S1	Hazardous stainless steel yoke with 18" leads and ground lead	2K	208/60
		L1	18" leads, 10 Watt Class F			2W*	110-120,50/60
		L2	18" leads, 10 Watt Class H			3W*	220-240,50/60
		L3	18" leads, 22 Watt Class H				
		S1	Screw Terminal, 10 Watt Class F				
		S2	Screw Terminal, 10 Watt Class H				
		S3	Screw Terminal, 22 Watt Class H				
		T1	1/4" Tab Terminal, 10 Watt Class F				
			Conventional Coils				
		J1	18" leads, 10 Watt Class F				
		J2	18" leads, 10 Watt Class H				
		J3	18" leads, 22 Watt Class H				
			Specialty Coils				
		F6	Fluxtron 4-wire, 1 Watt molded				
		J6	Fluxtron 2-wire, 1 Watt molded				
		J0	Magnelatch 2-wire DC only				
		G0	Magnelatch 3-wire AC/DC (DC pulse)				

+ See Note on page 133.









* Fluxtron only

ELECTRICAL ENCLOSURE OPTIONS

A coil enclosure is needed to complete the magnetic flux path of conventional molded coils and specialty coils. The enclosure can also serve to protect the coil and provide a means to accommodate the electrical connection. This section describes the most common electrical enclosure options available.

7000 Series Enclosure Options

7000 Series integrated coils incorporate these features into a one-piece assembly which requires only a nut and washer (enclosure code N0) to fasten to the pressure vessel. The 7000 Series conventional enclosure selection is provided to complement the integrated coil offering providing flexibility in product type and installation.

Coil Picture	Enclosure Code	Description	Applicable Coils
	A0	Standard Connection, 7/8" exit to accommodate strain relief, adapter or fittings for lead wires, NEMA Type 2	J111, J222, J322, F611, J611
	B0	1/2" Conduit Connection for attachment of conduit, 1/2" NPT fittings or BX cable, NEMA Type 2	F611, J611
	F0	Yoke for use where open enclosure is suitable	F611, J611
	G0	Watertight, 1/2" conduit hub accommodating 1/2" NPT fittings or BX cable, NEMA Type 4X	F611, J611
	J0	Splice box, 7/8" exit allowing for internal splice, NEMA Type 2	J111, J222, J322, F611, J611
	M1	Magnelatch, 1/2" conduit hub for attachment of conduit, 1/2" NPT fittings or BX cable, NEMA Type 2	G011, J011
	M2	Magnelatch, leaded with grommet connection, NEMA Type 2	G011, J011
	N0	Nut and Washer	All Integrated Coils

7000 Series Electrical Options

Various electrical options are available with 7000 Series integrated coils. To order a coil with an option, write the electrical option code in place of the last two digits of the coil code. The electrical options (with exception of the ground lead) are also available for sales as individual pieces (accessories). For an accessory, simply order the code.

7000 Series Mechanical Options

Solenoid valves at times requires a variety of different mechanical options to meet the specific needs of a given application. Many of these options have become common over time, others are specified infrequently.

Skinner has the ability to produce wide varieties and combinations of mechanical options. Listed are only a few of the common options we provide. If the option (or set of options) you need is not listed, please contact a company representative for assistance.

Available options are denoted by the valve family to which they pertain. The 7000 Series family designator is position 5 of the pressure vessel number. Codes that are suffixed by an asterisk (*) are already covered in the product listing in the catalog. To order the other listed mechanical options:

- 1) Select the base pressure vessel number. It must have "00" in the last two digits.
- 2) Confirm compatibility of the option with the Mechanical Options Table.
- 3) Write the mechanical option code in place of the last two digits of the pressure vessel number. For example, a 71215SN1MN00 with a manual override (M0) becomes 71215SN1MNM0.

Coil Option Picture	Coil Option Code	Description	Coil Types	Coil Codes
	GL	Ground Lead 18"	Conduit Terminated	C1GL, C2GL, C3GL H1GL, H2GL, H3GL
	D1*	Cable Gland DIN Plug	DIN	D1D1, D2D1, D3D1
	D2*	1/2" Conduit DIN Plug	DIN	D1D2, D2D2, D3D2
	D4#	Timer, 12-48VDC 24-120, 50/60 Hz	DIN, AC & DC	D1D4, D2D4, D3D4
	DB^	Terminal Box	DIN	D1DB, D2DB, D3DB
	TB^	Terminal Box	Screw Terminal	S1TB, S2TB, S3TB

* The plug comes complete with gasket to meets NEMA specification Type 4

The timer has a fixed "off" time of 12 minutes and an adjustable "on" time which ranges from 1 second to 2 minutes. The timer complete with 24" 3-wire cable. Also available on Timer Drain

Valves 7321KBY61640, 7321KBY63200, and 7321KBY6320A on page 25.

^ Meets NEMA 4, 4X when connected to a Screw Terminal or DIN Coil, as applicable. It is provided with a 1/2" NPT conduit thread and ground screw.

Code	Mechanical Options Descriptions	7000 Series Valve Families (pressure vessel 5th digit)												
		1	2	3	4	5	6	8	9	E	F	G	K	T
A2	Silver Shading Ring		X	X		X	X	X						
C0*	Anti-Water Hammer, 4 step adjustment												X	
J0	Pilot Exhaust Return Pipe		X											
J1	Exhaust Adapter Nut		X	X		X			X	X	X		X	
M0#	Manual Override		X			X								X
M5	M0 w/ Exhaust Adapter Nut					X			X					
MC*	Manual Override w/ Anti-Water Hammer, 4 step Adjustment												X	
MJ	M0 w/ Pilot Exhaust Return Pipe		X											
R0	Exhaust Metering			X		X								
R1**	Main Stream Metering			X		X								
R2**	Adjustable Bypass					X								
S0*	Steam Service Rated								X				X	X
W0*	Anti-Water Hammer, Fixed													X

Note: Not all options designated in this table are applicable to every valve within the valve family. Some exceptions are noted below. For details on specific valve option compatibility, consult the factory.

Not available on the following valve series: 71225, 71295, 7122K, 72218, 72228, 7221G, 7322G, and 73222. Not

available on 3/8" NPT or 1/2" NPT "5" and "K" family valves. ** Not available on 3/8" NPT valves.

Agency Approval Note: Valves listed as Safety Shutoff Valves (SS in catalog listings) are not permitted with Manual Override and/or Bypass Options (M0, MC, M5, R1, R2 above). Valves with these options are considered General Purpose Valves.

Agency Approvals

Most Skinner solenoid valves are approved by Underwriter's Laboratories (UL) and certified by the Canadian Standards Association (CSA). The table below summarizes the specific approvals obtained, which are dependent upon the combination of approved pressure vessels, coils and enclosures for both ordinary and hazardous locations.

Agency Approved Solenoid Valve Combinations

Enclosure Code	Coil* Type/Option	Metallic Bodied Pressure Vessels (Aluminum, Brass, Stainless Steel, Zinc)			Plastic Bodied Pressure Vessels** (Noryl, PTFE) All Porting Types				
		NPT ported	BSP ported	FLG mounted					
NO	C111, C222, C322	UL Listed							
NO	C1GL, C2GL, C3GL								
NO	D1DB, D2DB, D3DB								
A0,B0,G0,J0	F611, J611								
A0,J0	J111, J222, J322								
NO	H111, H222, H322								
NO	H1GL, H2GL, H3GL								
NO	S1TB, S2TB, S3TB								
NO	D100, D1D1, D1D2					UL Component Recognized			
NO	D200, D2D1, D2D2								
NO	D300, D3D1, D3D2								
FO	F611, J611								
NO	L111, L222, L322								
NO	S100, S200, S300								
NO	T100								

UL approved valves are also CSA certified. NOTE: Agency approval is contingent upon factory assembly of solenoid valves.

* Coil voltage must also be approved. See pages 12 and 13.
** Pressure vessels must be approved as Safety Shutoff (SS) or General Purpose (GP) valves. See catalog sections.

Types of Protection of Solenoids for Hazardous Environments

Standards are established by the European Committee for Electro-Technical Standards (CENELEC). Degrees of Protection of electrical parts and operating temperatures are defined by various European standards.

The following charts show the Degree of Protection for the selected coils along with the maximum surface temperatures for each temperature code classification.

Protection Class	Degree of Protection
IP-65	Protection against ingress of dust (dust proof) Protection against contact with internal parts Protection against a water jet from a nozzle from all directions
IP-67	Protection against ingress of dust (dust proof) Protection against contact with internal parts Protection against water when the equipment is immersed in water under specific pressure and time conditions

Temperature Classification	Maximum Allowable Surface Temperature	
	°C	°F
T1	450	842
T2	300	572
T3	200	392
T4	135	257
T5	100	212
T6	85	185

Response Time

The response time of a solenoid valve depends on many factors such as voltage, frequency, pressure, media, temperature (including coil) and the type of valve. Variations in these factors can have a significant effect on the response time. The following tabulation lists the approximate response times for several different types of valves. The times given are for the valves to go from closed position to open or from open position to closed.

Valve Type	Response Time (milliseconds)
Direct Acting Valves	4-15
Small Pilot Operated Piston Valves	30-90
Large Pilot Operated Piston Valves	100-150
Small Pilot Operated Diaphragm Valves	30-60
Large Pilot Operated Diaphragm Valves	60-160
Direct Lift Diaphragm Valves	30-60

Operating Speed (Cycle Rates)

Operating speed is defined as the maximum number of cycles (On/Off) per minute that a solenoid valve is capable of completing. It is dependent upon the response time characteristics of the valve. Many of our small, short stroke, direct acting valves are capable of operating at rates over 2,000 cycles per minute. However, for normal operation lower cycle rates as shown are usually recommended.

Valve Type	Up To (cycles/min)
Direct Acting Valves	600
Small Pilot Operated Piston Valves	400
Large Pilot Operated Piston Valves	150
Small Pilot Operated Diaphragm Valves	300
Large Pilot Operated Diaphragm Valves	200
Direct Lift Diaphragm Valves	200

Vacuum

While many of our solenoid valves with elastomeric seals listed in this catalog can be used on vacuum, the standard 100% production leakage test does not ascertain that the valves are sufficiently tight for severe vacuum applications. We do, however, design, produce, and test many vacuum valves to meet specific customer requirements. Therefore, we invite you to consult us for your vacuum valve applications.

Fluid Temperature Limitations

32°F Minimum Fluid Temperature if moisture is present. Otherwise minus 40°F for direct acting valves with NBR seals, minus 10°F with FKM seals (minus 10°F for "4" family valves). For exceptions, consult Skinner.

7000 Series Coils

To determine the approximate Holding or Inrush Current for AC voltages including 24/60, 120/60, 240/60 and 480/60 volts in amperes, divide the voltage into the VA rating indicated in the AC Power

Consumption tables. DC valves have no inrush current. The current rating in amperes for DC valves are shown in the DC Table. Figures are based on nominal values and will vary slightly depending on operating voltage and coil tolerances.

Current (Amperes)

7000 Series DC Current Consumption Ratings			
Coil Type		12 Volt	24 Volt
10 Watt	Integrated	0.81	0.41
	Conventional	0.81	0.41
22 Watt	Integrated	1.64	0.83
	Conventional	1.64	0.83

Valve Type	7000 Series AC Power Consumption Ratings							
	10 watt Integrated Coils		10 watt Conventional Coils		22 watt Integrated Coils		22 watt Conventional Coils	
	VA Holding	VA Inrush	VA Holding	VA Inrush	VA Holding	VA Inrush	VA Holding	VA Inrush
71211, 71311, 71321, 71331, 71381	16	32	13	30	-	-	-	-
71214	16	29	14	27	-	-	-	-
71215 (3/64"-1/8" orifice)	16	31	14	28	35	54	35	54
71215 (5/32"-5/16" orifice)	17	35	14	33	34	61	34	61
71215 (3/8" orifice)	16	36	14	34	34	63	34	63
71216	17	32	15	31	-	-	-	-
7121F	18	32	16	30	35	56	35	56
7121K (EPDM seals)	19	36	18	34	-	-	-	-
7121K (NBR, FKM seals, 1/16"-1/8" orifice)	18	32	16	30	35	56	35	56
7121K (NBR, FKM seals, 5/32"-1/4" orifice)	18	36	16	34	-	-	-	-
7121K (NBR, FKM seals, 7/16" orifice)	18	37	16	35	35	65	35	65
7121V	19	36	19	36	39	66	39	66
71221	16	32	13	30	-	-	-	-
71225	20	32	18	30	-	-	-	-
7122K	20	32	17	30	-	-	-	-
71235, 71313, 71335, 71385, 71395, 73312	17	27	16	26	-	-	-	-
71295, 71315 (0.19"-0.25" orifice)	16	30	15	29	-	-	-	-
72218	17	41	15	38	-	-	-	-
7221G (NBR, FKM seals)	17	41	16	39	-	-	-	-
7221G (EPDM seals)	19	41	18	39	-	-	-	-
72228	20	46	18	43	47	80	47	80
73212 (1/4" orifice)	16	31	14	28	35	54	35	54
73212 (1/2"-1" orifice), 71315 (0.05"-0.11" orifice)	17	27	16	26	-	-	-	-
73216	17	32	15	31	-	-	-	-
73218	16	31	14	28	35	54	35	54
7321G, 7321H	18	32	16	30	35	56	35	56
7321K (EPDM seals)	19	41	18	39	-	-	-	-
7321K (NBR, FKM seals)	17	39	15	36	-	-	-	-
73222, 73228	20	32	18	30	-	-	-	-
7322G, 7322H	20	32	17	30	-	-	-	-
74232, 73322, 73382, 73419, 74332	17	27	16	26	-	-	-	-
7131E, 7131F, 7131K, 7133F, 7133K, 7341L, 7131T, 7132T, 7133T	17	31	15	29	-	-	-	-
	17	35	16	33	-	-	-	-

7000 SERIES ACCESSORIES

Mounting Brackets

Body mounting options are available on specific valve families. A listing is provided below:

MECHB2:

For 2-way "2" family valves with 3/8-inch or 1/2-inch NPT connections. 2-way valves only.

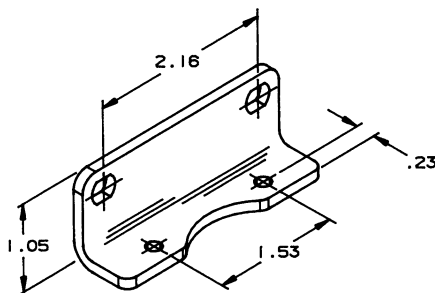

MECHB5:

For the "4", "5"(except 3/8" NPT) and direct operated "6" family valves(i.e. 71216), this bracket allows two different body mounting configurations.

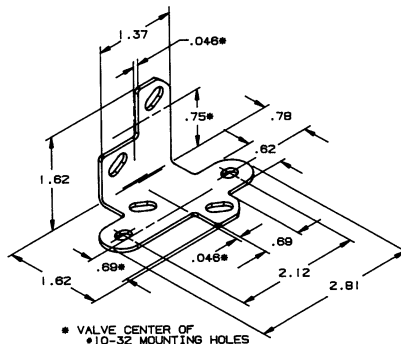

MECHB8:

For the "8" family, this bracket provides a flexible side mounting alternative.

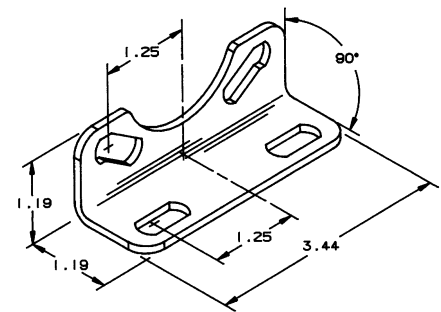

7000 Series Solenoid Valve Seal Materials

7000 Series solenoid valves are constructed with the finest elastomeric and plastic seal materials available to ensure dependable bubbletight operation and long life. Most of the valves in the catalog utilize a single seal material whether a plunger seal or a flange seal. However, many valve designs require a variety of different sealing materials.

The 7000 Series numbering system delineates the tenth digit for description of the main orifice seal – the seal that actually prevents flow through the valve. For direct acting valves this represents the

plunger seal and for pilot operated valves this represents the diaphragm. Since every seal material cannot be specified in the significant valve number, the following table can be used to determine the additional seal materials used.

Example: Valve No. 71215SN1EF00

Tenth digit F = Kel F seal material. Since this is a direct acting valve, the plunger seal is PCTFE.

From the table at left, we see that when a plunger seal is PCTFE, the flange seal is FKM. (this valve has no diaphragm)

Example: Valve No. 73218BN3TE00

Tenth digit E = EPDM seal material. Since this is

a pilot operated valve, the diaphragm is EPDM. From the table above, we see that when the diaphragm is EPDM, the plunger and flange seal is EPDM.

Standard Seal Material Combinations

Flange Seal	Diaphragm Seal	Piston Seal
NBR	NBR	NBR
FKM	FKM	FKM
Ruby	FKM	FKM
PCTFE	FKM	FKM
PFFPM	PTFE	PTFE
EPDM	EPDM	EPDM
PTFE	PTFE	PTFE
CR	CR	CR

Note: See Seal Material Designation Chart page 131.

Non-Standard Seal Material Combinations

There are some exceptions to the above standard. The following valve types do not conform to the table of standard seal material combinations and are therefore specified in this table. Non-metallic orifice materials are specified where applicable.

2-Way Valves

Catalog Number	Orifice (if non-metallic)	Plunger Seal	Flange Seal	Diaphragm Seal	Piston Seal	Other Seal
71216SN1BL00	Nylon	-	NBR	-	-	-
71216SN2BL00						
71216SN1GL00						
71216SN2GL00						
71216SN1FU00	Rulon	-	NBR	-	-	-
71216SN2FU00						
71216SN1JT00	PTFE	-	NBR	-	-	-
71216SN2JT00						
72228BN3TES0	-	FKM	EPDM	EPDM	-	EPDM, FKM
72228BN4UES0						
72228BN5VES0						
73216BN2MT00	Nylon	-	NBR	-	PTFE	NBR
73216SN2MT00	Polysulfone	-	NBR	-	PTFE	NBR
73222BN2MN00	-	FKM	NBR	-	NBR	NBR
73222SN2MN00						

NOTE: There may exist especially exacting application requirements which would necessitate a more detailed description of the various components and materials employed in the construction of Skinner solenoid valves. In such cases, contact the factory so that we may provide you with more detailed information.

Seal Material Designations

ASTM Designation	Commercial Designations and/or Trade Names	7000 Series Seal Designation
NBR	Buna-N, Nitrile	N
EPDM	Ethylene Propylene	E
FKM	Fluorinated Hydrocarbon, Viton®	V
PCTFE	Kel-F	F
PTFE	PTFE®, Rulon®AR	T
PFFPM	Kalrez	K
CR	Neoprene	C

Viton® is a Dupont Co. trademark.

Rulon®AR is a Furon-Advanced Polymers Division trademark

3- and 4-Way Valves

Catalog Number	Orifice (if non-metallic)	Plunger Seal	Flange Seal	Diaphragm Seal	Piston Seal	Other Seal
7131EBN2LN00	FKM	-	-	-	NBR	NBR
7131FBF4LV00	FKM	-	-	-	-	FKM
7133FBF4LV00						
7341LAN1HN00	FKM	-	-	-	NBR	NBR
7341LMN2NN00	FKM	-	-	-	NBR	NBR

NOTE: There may exist especially exacting application requirements which would necessitate a more detailed description of the various components and materials employed in the construction of Skinner solenoid valves. In such cases, contact the factory so that we may provide you with more detailed information.

Integrated Coils and Terminal Box Dimensions

The valve construction reference drawings provide outline dimensions for all pressure vessels contained in this catalog. They are shown with the 1/2" conduit style integrated coil as standard. The individual coil drawings on this page provide dimensions for the other 7000 Series integrated coils. To apply these coil dimensions to any of the standard valve construction references, a datum line (cL) has been included which corresponds to the conduit hub centerline dimension of the 1/2" conduit style integrated coil.

DRAWINGS

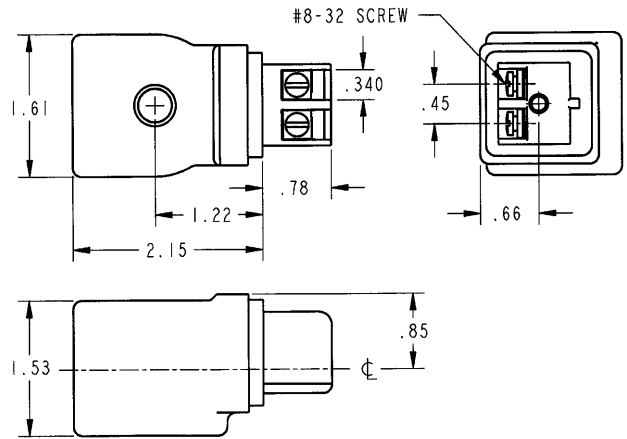

S100, S200, S300-Screw Terminations

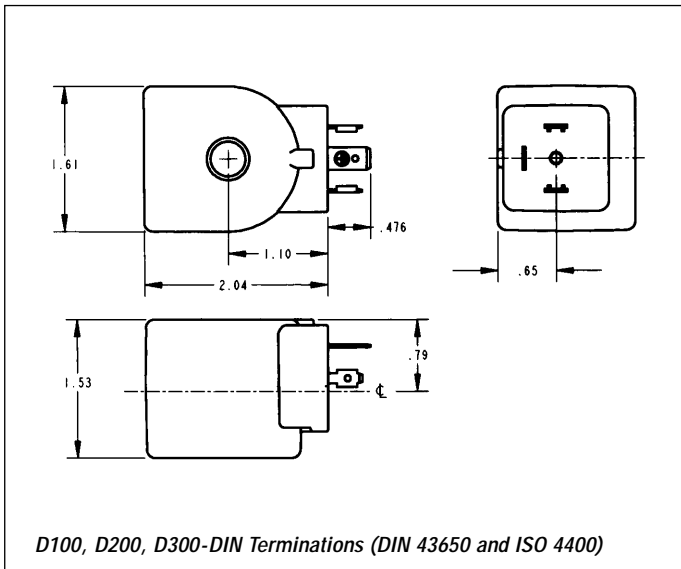

D100, D200, D300-DIN Terminations (DIN 43650 and ISO 4400)

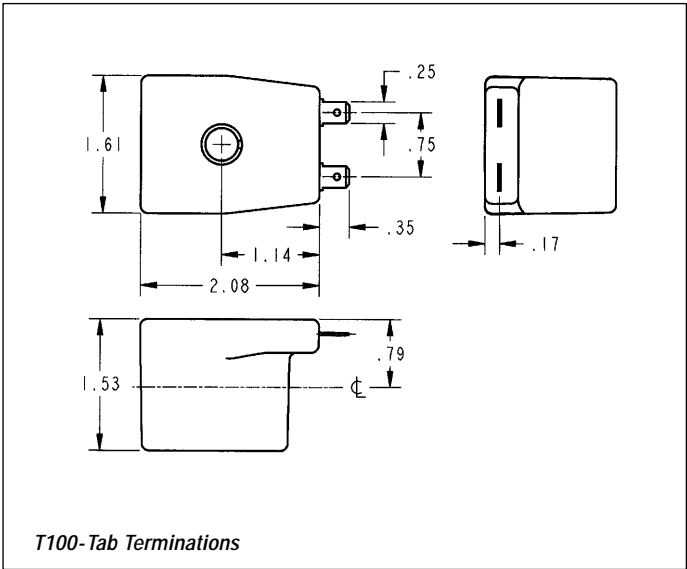

T100-Tab Terminations

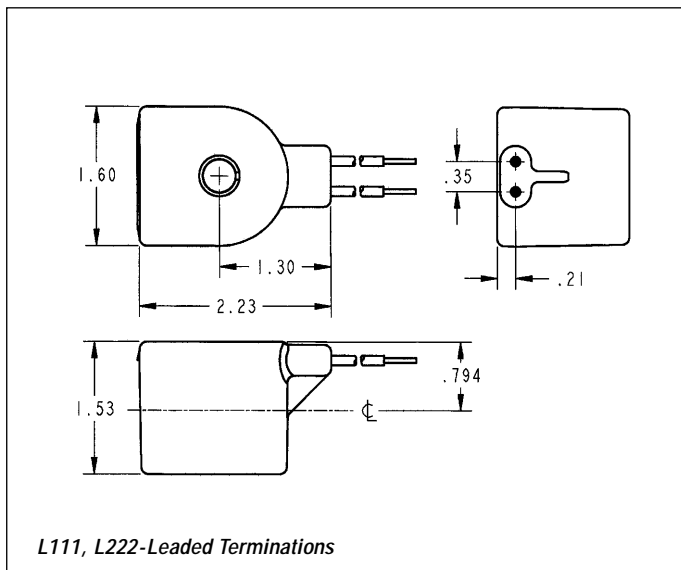

L111, L222-Leaded Terminations

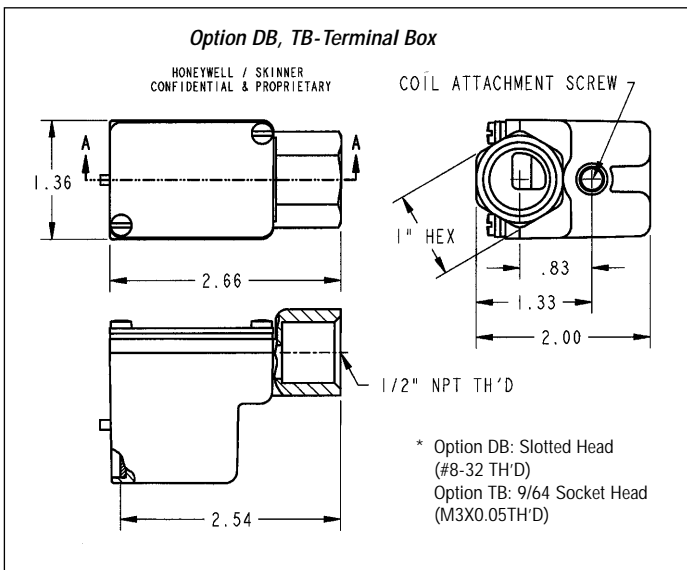





All dimensions in inches.

Electrical Enclosure Options

A coil enclosure is needed to complete the magnetic flux path of conventional molded coils and specialty coils. The enclosure can also serve to protect the coil and provide a means to accommodate the electrical connection. This section describes the most common electrical enclosure options available.

3000 Series Enclosure Options

3000 Series integrated coils are a one-piece assembly which requires only a nut and washer (enclosure code N0) to fasten to the pressure vessel. The 3000 Series conventional enclosure selection complements the integrated coil offering providing flexibility in product type and installation.

Coil Picture	Enclosure Code	Description	Applicable Coils
	RR	Grommet Enclosure	T1J1, T3J1
	BB	1/2" Conduit Connection	T1J1, T3J1
	YY	Yoke. For use where open enclosure is suitable	T1J1, T3J1
	N0	Nut and Washer for Integrated Molded coils	M1S1, M4S1 M3J5, M6J5
	N0	Nut and Washer for 1/2" Conduit NEMA coils	MC11, HC11

3000 Series Repair Kits/ Accessories

Repair kits are available for all Skinner 3000 Series valves. These kits include a new plunger assembly and plunger return spring. Specify the kit you need by the part number listed, which corresponds to the type of valve and seal material to be rebuilt.

Flow Pattern	NBR	Neoprene	EPDM	FKM
2-Way Normally Closed	3K3121N	3K3121C	3K3121E	3K3121V
2-Way Normally Open	3K3129N	3K3129C	3K3129E	3K3129V
3-Way Normally Closed	3K3131N	3K3131C	3K3131E	3K3131V
3-Way Normally Open	3K3139N	3K3139C	3K3139E	3K3139V
3-Way Multipurpose	3K3133N	3K3133C	3K3133E	3K3133V
3-Way Directional Control	3K3138N	3K3138C	3K3138E	3K3138V

Universal Mounting Bracket - B19-006 *Brass Adaptor with Gasket = 300-22-003* *SS Adaptor with Gasket = 300-22-004*

A, B, C, MB AND V9 SERIES INFORMATION

Coils

To determine the approximate Holding or Inrush Current for AC voltages including 24/60, 120/60, 240/60 and 480/60 volts in amperes, divide the voltage into the VA rating indicated in the AC Power

Consumption tables. DC valves have no inrush current. The current rating in amperes for DC valves are shown in the DC Table. Figures are based on nominal values and will vary slightly depending on operating voltage and coil tolerances.

A, B, C, MB and V9 Series

Valve Series	AC Power Consumption Ratings	
	VA Holding	VA Inrush
Two-way B	17	9.7
Three-way B	19	12
Two-way C	25	16
Three-way C	25	16
Two-way A	122	49
Three-way A	82	40
Three-way MB	12	6.5
Four-way MB	12	6.5
Four-way V9*	32.5	17.5

* Per coil

Valve Series	DC Current Consumption Ratings			
	6 Volt	Coil Type		
		12 Volt	24 Volt	120 Volt
Two-way B	1.05	0.53	0.26	0.05
Three-way B	1.05	0.53	0.26	0.05
Two-way C	1.17	0.58	0.29	0.06
Three-way C	1.17	0.58	0.29	0.06
Two-way A	-	-	-	-
Three-way A	2.33	1.17	0.58	0.12
Three-way MB	0.83	0.42	0.21	0.04
Four-way MB	0.83	0.42	0.21	0.04
Four-way V9*	1.42	0.71	0.35	0.07

* Per coil