

★ *Snap-Tite*

Thread
to
Connect
Couplings

78
SERIES

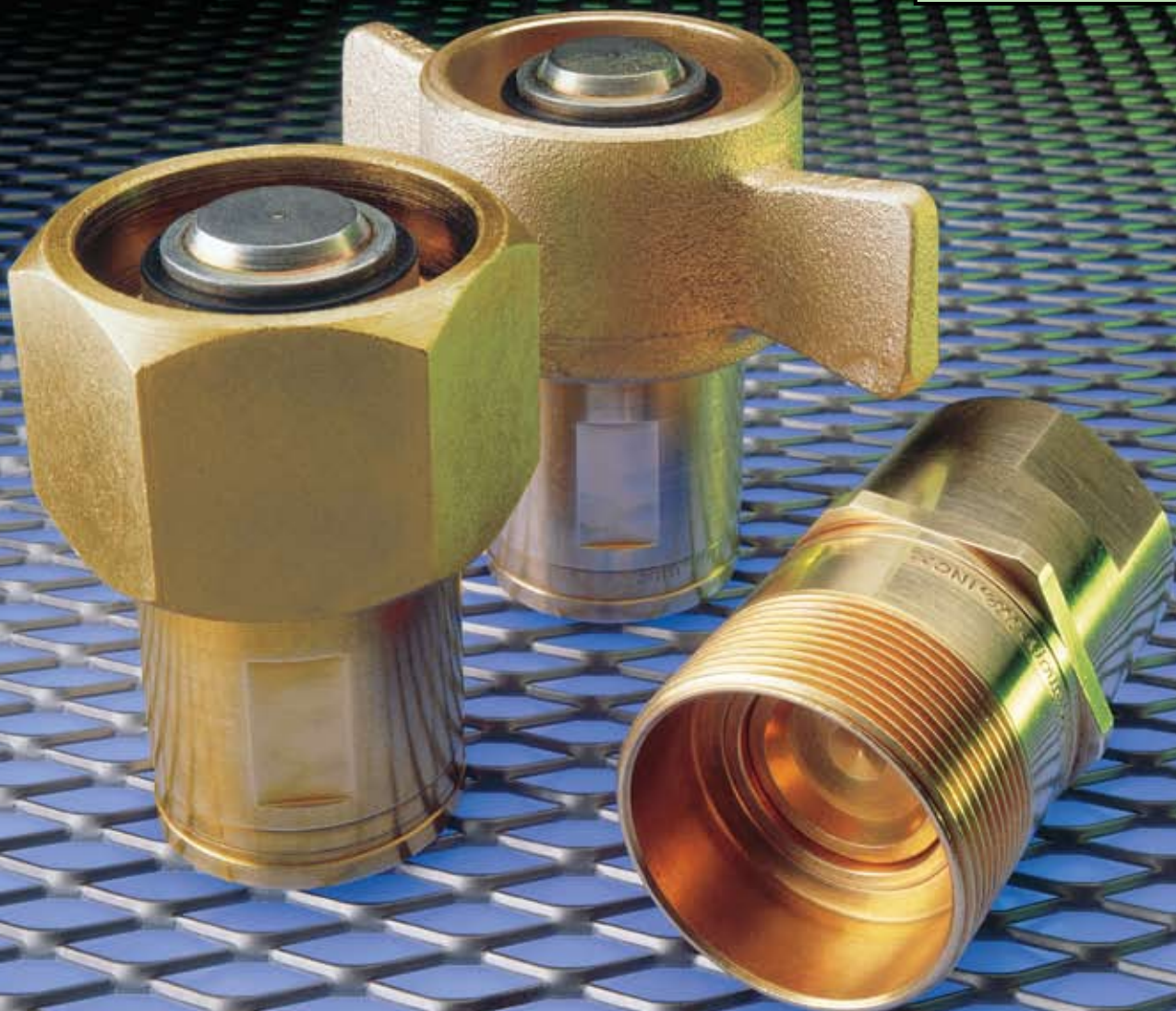

★ Snap-tite 78 Series — Thread-to-Connect Couplings

Featuring...Snap-tite quality with superior pressure and flow characteristics over the competition.



- Interchangeable with Aeroquip 5100 Series and Parker 6100 Series
- Heavy duty wing nut or hex nut for easy connection of threaded units
- 3,000 psig (207 bar) operating pressure
- 4,500 psig (310 bar) proof pressure
- Sizes 3/4", 3/4" x 1/2", 1", 1-1/4" and 1-1/2"

Snap-tite heavy duty 78 Series Thread-to-Connect Couplings are designed for most industrial fluid applications plus they are ideal for coal trucks, oil well equipment, hydraulic dump trucks, sand and salt spreaders requiring a rugged coupling.

The 78 series dry break features minimal spillage and air inclusion. The couplings connect under pressure. For bulkhead mounting, a steel flange is available. The 78 Series offers up to 3,000 psig (207 bar) operating pressure in both the connected and disconnected positions.

PRESSURE RATINGS

OPERATING PRESSURE* BRASS			AIR INCLUSION cc MAXIMUM	SPILLAGE cc MAXIMUM
SIZE	PSI	BAR		
3/4"	3000	207	.30	.15
1"	3000	207	.40	.40
1-1/4"	2750	190	.65	.65
1-1/2"	2500	172	.80	.85

*Pressure ratings for connected or disconnected modes.
For excessive flow and surge conditions, consult factory before specifying.

TECHNICAL AND DIMENSIONAL INFORMATION

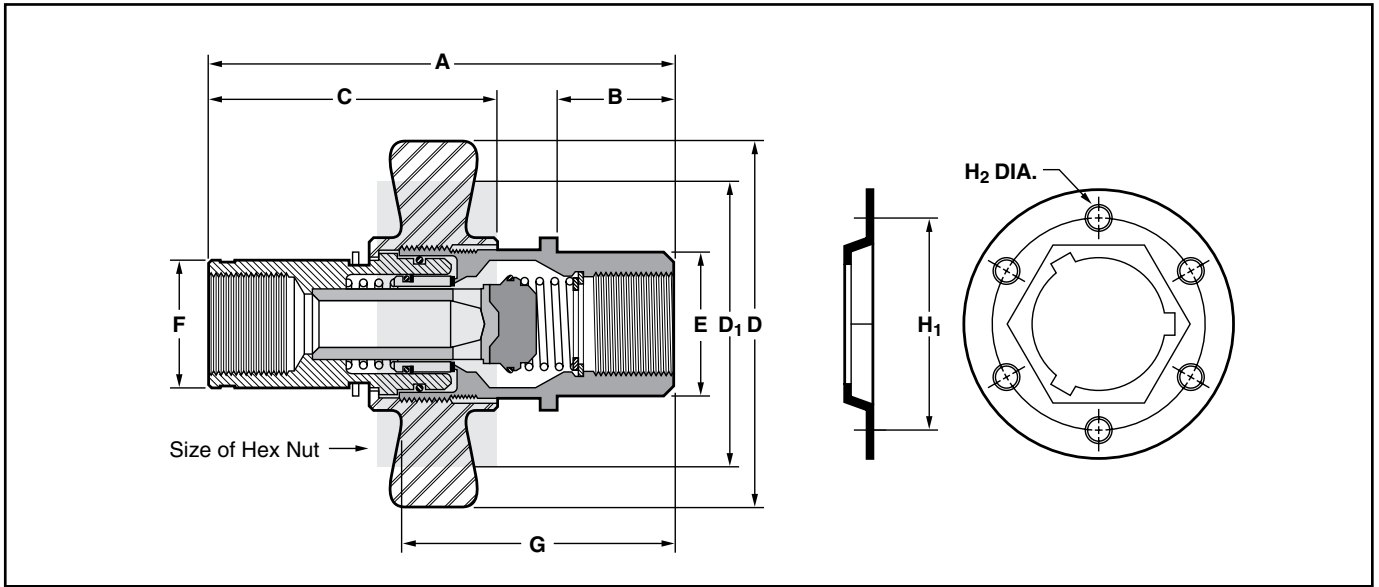

DIMENSIONS

SIZE	A		B		C		D		HEX D ₁		E		F		G		H ₁		H ₂	
	in	mm	in	mm	in	mm	in	mm	in	mm	in	mm	in	mm	in	mm	in	mm	in	mm
3/4"	5.02	127.51	1.66	42.26	2.93	74.42	4.10	104.14	1-3/4	44.45	1.44	36.58	1.25	31.75	3.11	79.00	2.13	54.10	.201	5.11
1"	5.45	138.43	1.38	35.05	3.44	87.38	4.50	114.30	2-1/8	53.98	1.74	44.20	1.57	39.88	3.24	82.30	2.38	60.45	.201	5.11
1-1/4"	6.28	159.51	1.78	45.21	3.92	99.57	5.23	132.84	2-1/2	63.50	2.08	52.83	1.89	48.00	3.73	94.74	2.63	66.80	.201	5.11
1-1/2"	6.54	166.12	1.63	46.40	4.09	103.89	5.25	133.35	2-3/4	69.85	2.45	62.23	2.18	55.37	4.13	104.90	3.25	82.55	.281	7.14

FLOW CHART

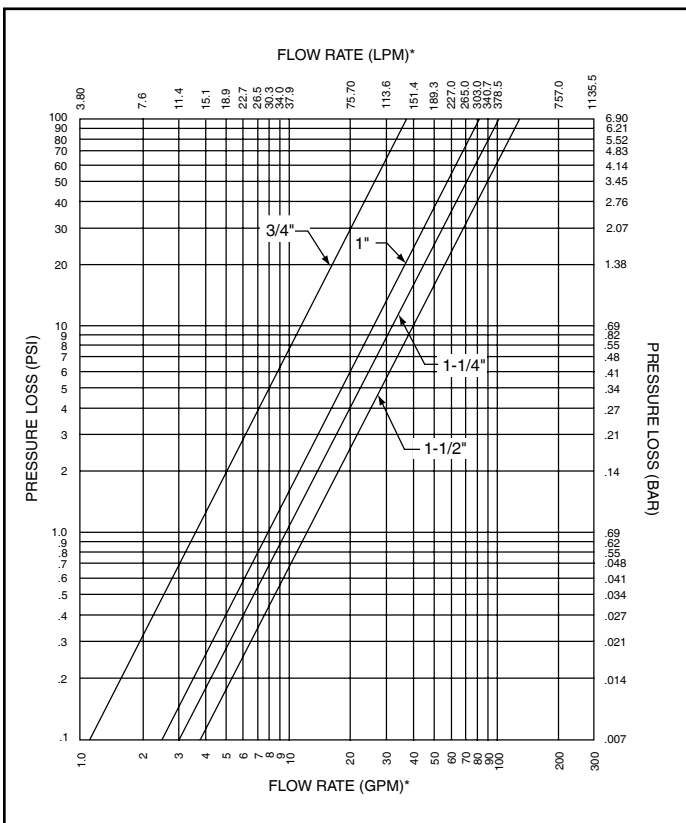

78 SERIES WITH WING NUT ASSEMBLY

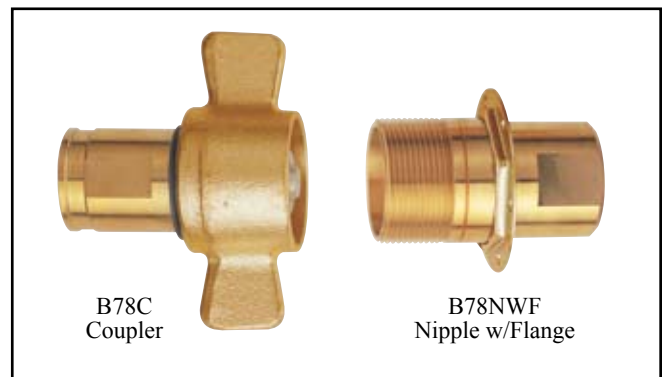

78 SERIES WITH HEX NUT ASSEMBLY

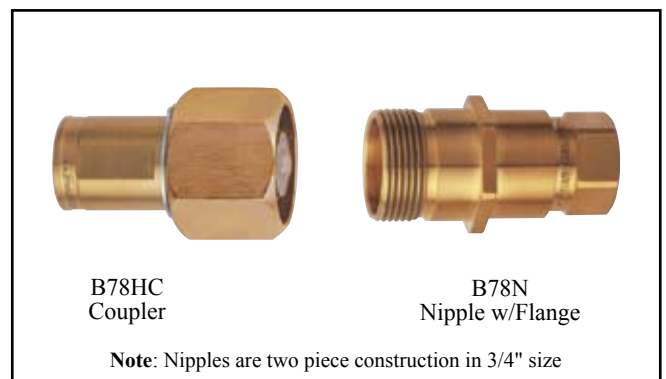

*150 ssu (32cSt) oil at 100°F (40°C).

HOW TO ORDER

PART NO. **B** **78** **H** **C** **12** - **12** **F**

Material	Series	Sleeve Configuration*	Coupling Half	Coupling Size	End Fitting Size	End Fitting Type	Nipple Flange*
B Brass	78	No Letter for Wing Nut H Hex Nut <i>*Coupler only</i>	C Coupler N Nipple	12 = 3/4" - 16 = 1" 20 = 1-1/4" 24 = 1-1/2"	8 † = 1/2" 12 = 3/4" 16 = 1" 20 = 1-1/4" 24 = 1-1/2"	F Female NPTF RP Female British Parallel BS2779	WF with flange <i>*Nipple only</i>

†Available in 1/2" Female NPTF only

ACCESSORIES*

Size	Protective Cap	Protective Plug	Mounting Flange
3/4"	78DC-12	78DP-12	78F-12
1"	78DC-16	78DP-16	78F-16
1-1/4"	78DC-20	78DP-20	78F-20
1-1/2"	78DC-24	78DP-24	78F-24

*All accessories are manufactured from carbon steel.

! WARNING !

FAILURE OR IMPROPER SELECTION OR IMPROPER USE OF THE PRODUCTS AND/OR SYSTEMS DESCRIBED HEREIN OR RELATED ITEMS CAN CAUSE DEATH, PERSONAL INJURY AND/OR PROPERTY DAMAGE.

This document and other information from Snap-tite, Inc., its subsidiaries and authorized distributors, provides product and/or system options for further investigation by users having technical expertise. It is important that you analyze all aspects of your application and review the information concerning the product or system in the current product catalog. Due to the variety of operation conditions and applications for these products or systems, the user, through its own analysis and testing, is solely responsible for making the final selection of the products and systems and assuring that all performance, safety and warning requirements of the application are met.

The products described herein, including without limitation, product features, specifications, designs, availability and pricing, are subject to change by Snap-tite, Inc. and its subsidiaries at any time without notice.



Quick Disconnect & Valve Division
201 Titusville Road
Union City, Pennsylvania 16438-8699 USA
PH: 814-438-3821 FAX: 814-438-3069
e-mail: qd&v_sales@snap-tite.com
www.snap-tite.com



Industrial Estate
Whitemill - Wexford
Republic of Ireland
PH: 353 53 914 1566 FAX: 353 53 914 1588
e-mail: ste_sales@snap-tite.com
www.snap-tite.com

DISTRIBUTED BY:

信德迈科技(北京)有限公司 CNMEC Technology

电话: 010-8428 2935, 8428 9077

网址: <http://www.cnmec.biz>

电邮: sales@cnmec.biz

传真: 010-8428 8762

地址: 北京市朝阳区胜古中路2号金基业大厦201室

ISO-9001 Certified